

Features & Functions Guide



NIRO
Electric Vehicle (EV)

WELCOME TO THE KIA FAMILY!

Your new Kia vehicle has been designed, engineered and manufactured to provide you with years of comfortable and dependable driving. Kia is committed to quality, innovation, safety and — above all — your satisfaction.

USING THIS FEATURES & FUNCTIONS GUIDE

The information contained in this guide is a brief overview of the operation and features of your new Kia vehicle.

This Features & Functions Guide and the specific operational and safety information it provides are not a substitute for your Owner's Manual. In the interest of your safety and that of the vehicle's occupants, and to help you avoid risks that may result in death or serious injury, Kia reminds you to carefully read the Owner's Manual in order to fully familiarize yourself with the important information and safety warnings it contains.

While Kia endeavors to ensure that the information contained in this guide is accurate at the time of printing, Kia may change vehicle specifications without notice in advance of or after the fact and assumes no liability in connection with such changes.

VIDEOS AND QR CODES

Kia provides a number of video resources to assist you with becoming familiar with the features and functions found in your Kia vehicle. You can access these resources by snapping the QR Codes with your mobile device using the built-in QR Code Reader or a downloaded QR Code Reader App.

After opening the QR Code Reader App on your mobile device, the app will utilize your device's camera. Center the code in the camera viewing area — with some apps, as soon as the app recognizes the code, it will launch the corresponding video.

With other apps, you will have to snap or "take a picture" of the code. The app will then launch the corresponding video.

For operation specifics, refer to the instructions that come with the QR Code Reader App. You can also view the videos by visiting the following website: www.youtube.com/KiaFeatureVideos

QUICK TIPS

If you're having trouble scanning codes, check the following:

- The code should be centered and focused in your mobile device's camera screen
- Consider moving your device closer to or farther away from the code
- The code should be well lit, without significant shadow
- Avoid scanning from a significant angle
- Confirm that the device's app supports 2D QR Code scanning
- Try another QR Code Reader App; not all apps are created equal

After scanning, you may experience a "connection error" message or a "connecting" message with no subsequent response. These messages typically indicate that your device is having trouble connecting to the Internet

QR CODES

Instrument Cluster's LCD Display Video



Refer to the inside front cover for more information on QR codes.
www.youtube.com/KiaFeatureVideos

As you get to know your new Kia, you can explore this booklet to better understand how to operate its many features and systems. You can find the complete Table of Contents on the next two pages, but first, be sure to review the following to better understand some of your Kia's most used features:

1	Smart Key	53
2	Power Adjustable Driver's Seat / Front Seat Headrest Adjustment	50
3	Seat Warmers*	49
4	Folding Rear Seats	51
5	Windshield Wipers & Washers.	36
6	Smart Cruise Control (SCC)* with Stop & Go.	26
7	Normal Maintenance Schedule	Back Cover
8	User Settings - Instrument Cluster	10
9	Vehicle Settings* - Audio Head Unit	11
10	Bluetooth® Wireless Technology	38-39
11	UVO link Activation* / UVO Assistance*	41
12	Kia Access with UVO link App Download	42
13	Kia Access with UVO link App Features Guide	42
14	UVO link with Navigation*	43
15	Android Auto™ / Apple CarPlay® Setup.	40

Driving while distracted can result in a loss of vehicle control that may lead to an accident, severe personal injury and death. The driver's primary responsibility is in the safe and legal operation of a vehicle, and handheld devices, other equipment or vehicle systems which take the driver's eyes, attention and focus away from the safe operation of a vehicle or that are not permissible by law should never be used during operation of the vehicle.

www.kia.com
 Consumer Affairs - Roadside Assistance¹¹:
 1-800-333-4KIA (800-333-4542)

Always check the Owner's Manual for complete operating information and safety warnings.

VIDEOS & QR CODES . . . Inside Front Cover

INSTRUMENT CLUSTER

Instrument Cluster Overview 03
 Indicators & Warning Lights 04
 Electric Vehicle (EV) Indicators 05
 Energy Consumption 05
 Charge Warning Messages on LCD Display 06
 Tire Pressure Monitoring System (TPMS) 08
 Drive Mode Integrated Control System 12

VEHICLE SETTINGS

LCD Instrument Cluster Modes 09
 Trip Modes / Trip Computer 09
 User Settings - Instrument Cluster 10
 Vehicle Settings* - Audio Head Unit 11
 Service Interval Mode 11

ELECTRIC VEHICLE (EV) FEATURES

Charging Connector Auto/Lock Mode 13
 Scheduled Charging* 13
 Charging Your Electric Vehicle 14
 EV Mode - UVO link with Navigation* 16
 Regenerative Braking with Paddle Shifters 18

ADVANCED DRIVER ASSISTANCE SYSTEMS (ADAS)

Blind-Spot Collision-Avoidance Warning (BCW) 19
 Rear Cross-Traffic Collision Warning (RCCW) 19
 Lane Keeping Assist (LKA) 20
 Lane Following Assist (LFA) 22
 Forward Collision-Avoidance Assist (FCA) 23
 Highway Driving Assist (HDA)* 24
 Leading Vehicle Departure Alert (LVDA) 25
 Smart Cruise Control (SCC) with Stop & Go* 26
 Navigation-based Smart Cruise Control - (NSCC)* 27
 Cruise Control 27
 Driver Attention Warning (DAW)* 28
 Rear Occupant Alert (ROA) with Door Monitoring 29
 Reverse Parking Distance Warning (PDW)* 30
 Rear View Monitor (RVM) 30

DRIVER'S PANEL

Instrument Cluster Control 31
 Electronic Stability Control (ESC) 31
 Hill-Start Assist Control (HAC) 31
 Power Button 32
 Power Windows, Window Lock & Central Door Lock 33
 Automatic Door Lock 33
 Power/Heated Outside Mirrors 33
 Power Folding Outside Mirrors 33

STEERING WHEEL CONTROLS

Headlights & High Beams 34
 Turn Signals & Fog Lights* 35
 Tilt/Telescoping Steering Wheel 35
 Windshield/Rear Wipers & Washers 36

AUDIO SYSTEMS

Audio Controls 37
Bluetooth® Wireless Technology 38
 Android Auto™ / Apple CarPlay® Setup 40
 UVO link Activation* 41
 UVO Assistance* 41
 Kia Access with UVO link App Download 42
 Kia Access with UVO link App Features Guide 42
 UVO link with Navigation* 43

CENTER PANEL

Digital Clock 44
 USB Charger Ports* 44
 Multimedia USB Ports & Power Outlets* 44
 Wireless Smartphone Charging System* 45
 Automatic Climate Control 46
 Rotary Dial Shifter Knob 47
 Heated Steering Wheel Button* 47
 Electronic Parking Brake (EPB) 48
 Auto Hold 48
 Seat Warmers / Ventilated Seats* 49

SEATING

Front Seat Headrest Adjustment 50
 Power Adjustable Driver's Seat* 50
 Folding Rear Seats 51

OTHER KEY FEATURES

Hood Release Lever and Latch 52
 Sunvisor 52
 Smart Key 53
 Double-Turn Lock/Unlock All 53
 Map/Room Lamps 54
 Sunroof Operation* 54
 Liftgate Release Button* 55
 Child-Protector Rear Door Lock 55
 Tire Mobility Kit 55

SAFETY FEATURES

Occupant Detection System (ODS) / Passenger Airbag Off Indicator 56
 Seat Belts 56

MAINTENANCE CHART Back Cover

LEGAL DISCLAIMERS Inside Back Cover

Instrument Cluster Overview

- A** POWER - Energy consumption rate
- B** CHARGE - Charge/discharge status of the regenerative brakes
- C** Battery State of Charge (SOC) gauge
- D** Speedometer
- E** Warning and indicator lights
- F** LCD display
- G** Remaining distance

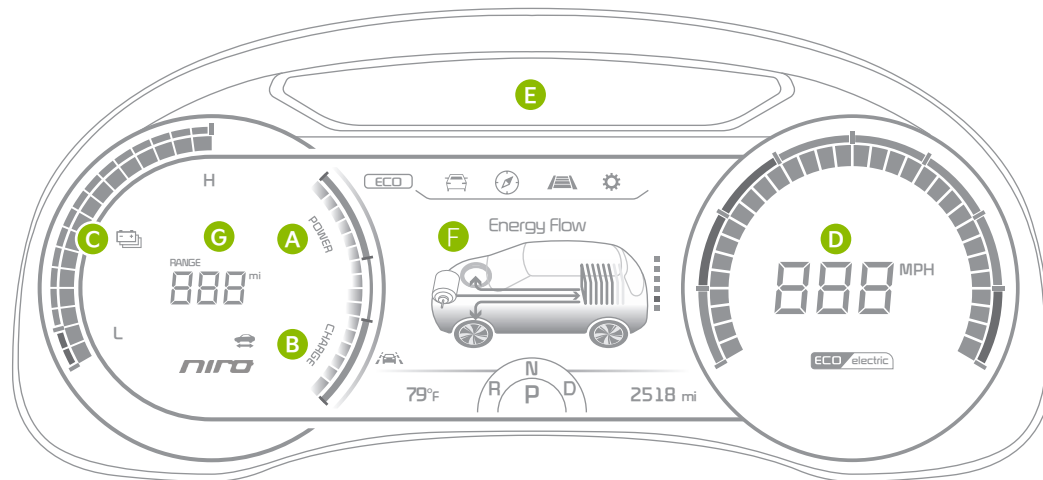

Your vehicle's instrument cluster & indicator light locations may differ from those in the illustrations. For more information on the instrument cluster, the LCD Warning Messages and the function of all indicator and warning lights, please refer to section 4 of the Owner's Manual.





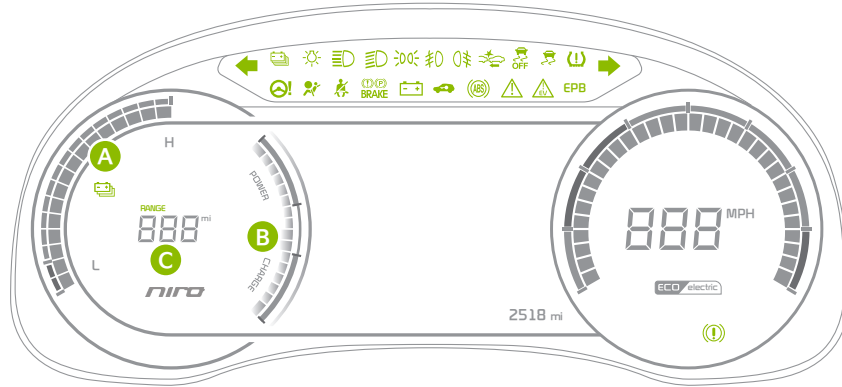





This illustration is for demonstration purposes only. Some indicators and warning lights may not appear in illustration. On the vehicle, they may appear in the LCD.

Indicators & Warning Lights











Your vehicle's instrument cluster & indicator light locations may differ from those in the illustrations. For more information on the instrument cluster, the LCD Warning Messages and the function of all indicator and warning lights, please refer to section 4 of the Owner's Manual.

This illustration is for demonstration purposes only. Some indicators and warning lights may not appear in illustration. On the vehicle, they may appear in the LCD.

-  High Beam Indicator
-  Light ON Indicator
-  Front Fog Light Indicator*
-  Master Warning Light
-  Forward Safety Warning Indicator
-  Lane Keeping Assist (LKA) Indicator*
-  Electronic Brakeforce Distribution (EBD) System Warning Indicator (Two separate indicators on Instrument Cluster lit at same time)
-  Immobilizer Indicator*
-  READY Indicator
-  ECO Mode Indicator
-  ECO+ Mode Indicator

-  SPORT Mode Indicator
-  EV Service Warning Light
-  EV Temperature Warning*
-  Charging System Warning Indicator
-  Seat Belt Warning Indicator
-  Low Tire Pressure Light / Tire Pressure Monitoring System (TPMS) Malfunction Indicator*
-  Electronic Stability Control (ESC) Indicator / ESC Malfunction Indicator
-  Electronic Stability Control (ESC) OFF Indicator
-  Parking Brake & Brake Fluid Warning Indicator
-  Electronic Power Steering (EPS) Warning Indicator
-  Airbag Warning Indicator
-  Anti-lock Braking System (ABS) Warning Indicator

-  CRUISE Indicator*
-  Regenerative Brake Warning Indicator (Two separate indicators on Instrument Cluster lit at same time)
-  LED Headlamp Warning Indicator*
-  Charging Cable Connection Indicator
-  Power Down Warning Light
-  High Voltage Battery Level Warning Light
-  12V Battery
-  EPB Electronic Parking Brake (EPB)

Electric Vehicle (EV) Indicators

A State of Charge (SOC) gauge

The State of Charge gauge displays the high-voltage battery charge status.

- L (low) position on the gauge indicates that the driving battery energy is low
- H (high) position on the gauge indicates that the driving battery is fully charged

B Power / Charge Gauge

Niro EV's Power / Charge gauge provides information on the energy consumption rate of the vehicle and the charge status of the regenerative brakes.

- **POWER** - Shows the energy consumption rate of the vehicle when driving uphill or accelerating. The more electric energy used, the higher the gauge level
- **CHARGE** - Shows the charging status of the battery when it is being charged by the regenerative brakes. The more electric energy charged, the lower the gauge level

C Remaining Distance

Remaining Distance is the estimated distance the vehicle can be driven with the remaining high-voltage battery level. It is displayed differently according to the selected drive mode and Climate Control settings.

For more information, refer to the Owner's Manual.



Ready indicator light - Illuminates when the vehicle is ready to drive. When the ready indicator light is blinking, a malfunction has occurred. Have an authorized Kia dealer address the concern as soon as possible.



EV Service warning light - Illuminates when there is a malfunction related to the electric vehicle control system. Have an authorized Kia dealer address the concern as soon as possible.



Power down warning light - Illuminates when the vehicle's speed and performance are limited for the safety of the electric vehicle.



Charging indicator light - Shows the charging status of the high-voltage battery. When charging, the red indicator turns on. The indicator turns off when not charging.



High-voltage battery level warning light - Illuminates when the high-voltage battery charge level is insufficient.



Regenerative brake warning lights (when both indicators are lit) - Illuminates when the regenerative brake system is not functioning correctly.

Energy Consumption

There are several factors that contribute to your electric vehicle's energy consumption, including maintenance of your vehicle, driving style, environmental conditions, vehicle weight and vehicle aerodynamics.

Below are tips on how to help reduce energy consumption:

- Keep your vehicle in good condition with regular maintenance
- Don't "ride" the brake pedal
- Drive at a moderate speed, accelerating smoothly and at a moderate rate
- Keep tires inflated to the recommended pressure
- Travel lightly, without carrying unnecessary weight in your vehicle
- Ensure wheels are aligned correctly
- Avoid placing large or heavy items on roof racks
- Avoid hilly, winding or poorly maintained roads

For more information, refer to section 6 of the Owner's Manual.

Charge Warning Messages on LCD Display

Low EV Battery



Low Battery Warning - When the high-voltage battery level reaches 8% or less, this warning message appears on the LCD and the warning indicator light on the instrument cluster illuminates. Charge the high-voltage battery immediately.

Charge immediately.
Power limited



Charge immediately. Power limited - When the high-voltage battery level reaches 3% or less, this warning message appears on the LCD, the warning indicator light on the instrument cluster illuminates and the power down warning light turns ON simultaneously.

The vehicle's power will be reduced to minimize the energy consumption of the high-voltage battery. Charge the high-voltage battery immediately.

Power limited



Power limited - This warning message appears when the vehicle's power is limited due to the following reasons:

1. When the high-voltage battery is below a certain level, or voltage is decreasing
2. When the temperature of the motor or high-voltage battery is too high or too low
3. When there is a problem with the cooling system or a failure that may interrupt normal driving

Power limited
due to low EV battery
temperature.
Charge battery

Power limited due to low EV battery temperature. Charge battery - When the outside temperature is low and you turn the vehicle on or off, this warning message may appear on the LCD. If the battery level is low and the vehicle is parked outside for a long time, vehicle power may be limited. Charging battery before driving helps increase power.

EV Battery Overheated!
Stop Vehicle



EV Battery Overheated! Stop Vehicle - When the high-voltage battery temperature is too high, this warning message will appear on the LCD. Stop the vehicle and turn off the Power button so that the battery temperature decreases.

Stop vehicle and
check power supply



Stop vehicle and check power supply - When there is a failure in the power supply system, this warning message appears on the LCD. Park the vehicle in a safe location and have it towed to the nearest Kia dealer for inspection.

REMINDERS:

- When these warning messages are displayed, do not accelerate or start the vehicle suddenly
- All stored driving information (except Odometer and Range) is reset if the battery is disconnected

These illustrations are for demonstration purposes only. Some messages may appear differently. See your Owner's Manual for more information.

Charge Warning Messages on LCD Display (Continued)

Unplug vehicle to start



Unplug vehicle to start - When starting the vehicle while the charging connector is still connected, this warning message will appear. Remove the charging connector and then start the vehicle.

Charging Door Open



Charging Door Open - When starting the vehicle while the charging door is still open, this warning message will appear. Close the charging door after charging is complete and then start the vehicle.

Charging Stopped.
Check the AC charger

Charging Stopped.
Check the DC charger

Charging Stopped. Check the AC/DC charger - When there is a problem with the external AC or DC charger, when the AC charger stops charging or when the charging cable is damaged, this message will appear. Check whether there is a problem with the charger or cable. If no problem is found, see an authorized Kia dealer for further assistance.

Charging Stopped.
Check the cable connector



Charging Stopped. Check the cable connector - When the charging connector is not correctly connected to the charging inlet or the charging connector lock release button is pressed, this message will appear. If this occurs, separate the charging connector and re-connect it. Check whether there is any problem (external damage, foreign substances, etc.) with the charging connector and charging inlet. If the problem continues, see an authorized Kia dealer for assistance.



REMINDERS:

- When these warning messages are displayed, do not accelerate or start the vehicle suddenly
- All stored driving information (except Odometer and Range) is reset if the battery is disconnected

Illustrations are for demonstration purposes only. Some messages may appear differently. See your Owner's Manual for more information.

Tire Pressure Monitoring System (TPMS)^{†19}

The TPMS indicator  functions as both Low Tire Pressure Light and TPMS Malfunction Indicator. The indicator  will illuminate if it detects one or more tires is significantly underinflated, the vehicle has a spare tire installed without TPMS or the outside temperature becomes significantly lower.

The LCD screen in the instrument cluster will display the Low Tire Pressure indicator  showing which tire(s) is underinflated. Inflate tire(s) to specifications using an accurate digital tire pressure gauge to turn off Low Tire Pressure Light . See front driver's door jamb for PSI specification.

When there is a problem with the TPMS, the TPMS Malfunction Indicator  will blink for approximately one minute then illuminate - see dealer for service.

QUICK TIPS

- Even with TPMS, tire pressure should be checked manually at least once a month. Only adjust tire pressure on "cold tires" that have been sitting for sitting for 3 hours or more, and, and tires that are not hot in temperature from direct sunlight or heat
- For proper maintenance and optimal fuel economy, maintain recommended tire inflation pressures and stay within the load limits and weight distribution recommended for your vehicle
- In winter or cold weather, the TPMS light may illuminate if the tire pressure was adjusted to the recommended tire inflation pressure during warm weather

REMINDERS:

- Check the recommended tire pressure label located on the left side of driver's door jamb, visible when the door is open
- Consult your dealer for service if Low Tire Pressure Light remains illuminated after inflating your tire(s)

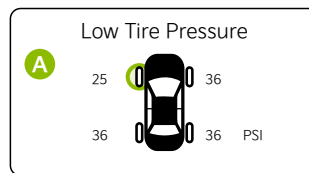

QR CODE

Tire Pressure Monitoring System Video



Refer to the inside front cover for more information on QR codes.
www.youtube.com/KiaFeatureVideos

Personal electronic devices (such as laptops, wireless chargers, remote start systems, etc.) may interfere with TPMS system, which may cause the Malfunction Warning Indicator (Check Engine Light) to illuminate.

For more information, refer to the Owner's Manual.

Drive Mode Integrated Control System

Niro EV is equipped with four distinct driving modes. Press the Drive Mode button **A** to select the desired mode.

ECO+ - This super power-saving mode is designed to help maximize battery energy. Press and hold the Drive Mode button **A** to select the ECO+ mode

ECO - This mode can help enhance efficiency by managing battery usage

NORMAL - This mode balances drivability and efficiency

SPORT - This mode provides enhanced acceleration and dynamic drivability

An indicator in the instrument cluster will illuminate to show which drive mode you have selected (no indicator will appear for the NORMAL mode).

QUICK TIPS

- To help reduce energy consumption:
 - Drive at a moderate speed, accelerating smoothly and at a moderate rate
 - Keep tires inflated to the recommended pressure and wheels aligned properly

For more information on Driving Modes, refer to your Owner's Manual or contact your local dealership.

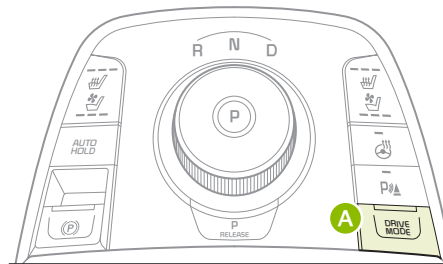

(Button located at right below Rotary Dial Shifter Knob)

QR CODE





Drive Mode Integrated Control Video



Refer to the inside front cover for more information on QR codes.
www.youtube.com/KiaFeatureVideos

LCD Instrument Cluster Modes

Press Mode button **A** to scroll through different LCD Instrument Cluster Modes.

-  **Trip Computer Mode:** Displays driving information for consumption info, accumulated info, drive info, driving style and energy flow
-  **Turn-by-Turn Mode*:** Displays the route guidance, destination info
-  **Driving Assist:** Displays information for Lane Departure Warning, Lane Keeping Assist, Smart Cruise Control, Lane Following Assist*, Highway Driving Assist*, Driver Attention Warning (DAW) and TPMS
-  **User Settings Mode:** Change settings for driver assistance, doors, lights, sound, convenience, service interval, other, reset
-  **Master Warning Mode:** Displays warning messages related to the vehicle when one or more function is not operating normally

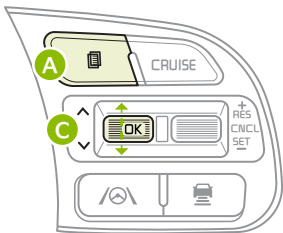

(Buttons located on Steering Wheel - Type A shown)

Your vehicle's steering wheel buttons may differ from those in the illustrations.

Driving while distracted is dangerous and should be avoided. Drivers should remain attentive to driving and always exercise caution when using the steering-wheel-mounted controls while driving.

Trip Modes / Trip Computer

The Trip Computer is a driver information system that displays information related to driving, such as Average and Instant accumulated info, drive info, driving style and energy flow. It appears on the display when the Engine Start/Stop button is in the ON position.

To cycle through the instrument cluster modes **B**, press the Mode button **A**.

When in the Trip Computer mode , press the Select/Reset (OK) button **C** to cycle through the screens. When displaying ACCUMULATED INFO or DRIVE INFO screens, press and hold the OK button **C** to reset to zero.

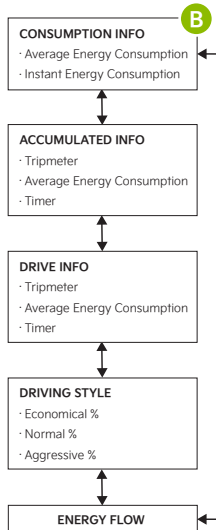

REMINDERS:

- Appearance of Trip Computer display may differ as equipped
- All stored driving information (except Odometer and Range) is reset if the battery is disconnected

QR CODE

Instrument Cluster's LCD Display Video



Refer to the inside front cover for more information on QR codes.
www.youtube.com/KiaFeatureVideos

User Settings - Instrument Cluster

To enter the User Settings mode in the LCD Instrument Cluster Modes, press the Mode button **A** when the vehicle is at a standstill, Rotary Dial Shifter Knob in Park while the Engine Start/Stop button is in the ON position. Then select User Settings  by pressing the Move/Reset (OK) button.

You can navigate the selections on the display by pressing the OK button **B** up/down, and then selecting the item by pressing the OK button **B** again.

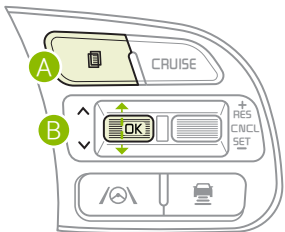

(Buttons located on Steering Wheel - Type B)

Driver Assistance:

- Lane Safety
- Driver Attention Warning (DAW)
- Smart Cruise Control (SCC) Reaction
- Leading Vehicle Departure Alert
- Lane Following Assist
- Highway Driving Assist
- Highway Auto Curve Slowdown
- Forward Collision-Avoidance Assist
- Forward Collision Warning
- Blind-Spot Collision Warning Sound
- Rear Cross-Traffic Collision Warning

Door:

- Automatically Lock
- Automatically Unlock
- Two Press Unlock

Lights:

- One Touch Turn Signal
- Ambient Light Brightness
- Ambient Light Color

Sound:

- Parking Distance Warning-Forward Volume*

Convenience:

- Utility Mode
- Rear Occupant Alert
- Welcome Mirror/Light
- Wireless Charging System*
- Wiper/Lights Display*
- Auto Rear Wiper
- Smart Regeneration
- Icy Road Warning

Service Interval:

- Enable Service Interval
- Adjust Interval
- Reset

Other features:

- Aux. Battery Saver+
- Energy Consumption Reset
- Temperature Unit
- Tire Pressure Unit

Reset:

- Choosing reset will restore defaults for all User Settings menus

QR CODE

Vehicle & User Settings Video



Ambient, Mood & Theme Lighting Video



Refer to the inside front cover for more information on QR codes.
www.youtube.com/KiaFeatureVideos

Driving while distracted is dangerous and should be avoided. Do not attempt to change vehicle system settings while driving.

Vehicle Settings* - Audio Head Unit

To enter the Vehicle Settings mode in the audio head unit **A**, press the SETUP hard key on the audio head unit. Then press Vehicle **🔧** onscreen, which will take you to Vehicle Settings. Use the touchscreen to navigate through the menus.

Vehicle Settings:

Driver Assistance*: Driving Convenience*, Warning Time*, Warning Volume*, Driver Attention Warning*, Forward Safety*, Lane Safety*, Blind-Spot Safety*, Parking Safety*

Drive Mode: Drive Mode Alert*

Climate*: Recirculate Air*, Automatic Ventilation*, Defog/Defrost Options*, Climate Features*

Lights*: Ambient Light*, One Touch Turn Signal*, Headlight Display*, High Beam Assist*

Door*: Auto Lock*, Auto Unlock*, Walk-Away Lock*, Two-Press Unlock*, Smart Trunk*

Cluster*: Service Interval*, Energy Consumption Reset*, Content Selection*, Cluster Voice Guidance Volume*, Welcome Sound*, Theme Selection*

Convenience*: Rear Occupant Alert*, Welcome Mirror Light*, Wireless Charging System*, Vehicle Auto-Shut Off*

Seat*: Seat Position Change Alert*, Smart Posture Care*, Heated/Ventilated Features*, Seat Easy Access*, Rear Seat Heating Control*

Reset*: Reset Vehicle Settings to Factory Defaults

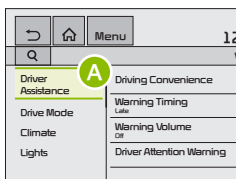

Service Interval Mode

To enter Service Interval mode, press the Mode button **B**, User Settings **⚙️**, then scroll to Service Interval Mode **👇** and press the OK button **C**. The system will display the number of miles remaining until next service is due, as well as type of service.

When service is required, the following will be displayed:

Service Required

To reset the Service Interval mode system, press and hold the OK button **C** for more than 1 second.

To turn the Service In message off, go to User Settings.

Service Interval Setting

To set the service interval when in User Settings mode:

- Press the OK button **C** up/down and scroll to Service Interval. Press the OK button **C** to enter
- Press the OK button **C** up/down then press the OK button **C** again. Then press the OK button **C** to scroll and select the desired miles or months for your next service
- Press the OK button **C** again

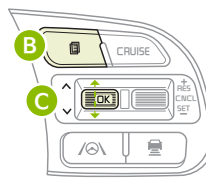

(Buttons located on Steering Wheel - Type B)

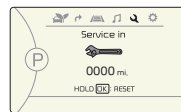
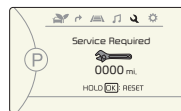

QR CODE

Vehicle & User Settings Video



Ambient, Mood & Theme Lighting Video



Refer to the inside front cover for more information on QR codes. www.youtube.com/KiaFeatureVideos

Driving while distracted is dangerous and should be avoided. Do not attempt to change vehicle system settings while driving.

Charging Connector Auto/Lock Mode

The Charging Connector can be set to be locked or unlocked while in the charging inlet and charging. Press the AUTO  button **A** (LED lit) for the connector to lock while charging and unlock automatically when charging is complete.

When the AUTO  button **A** is not pressed (LED not lit), the mode will be set to LOCK. The connector will be locked when charging and remain locked until all doors are unlocked.

QUICK TIPS

- If in lock mode & the doors are unlocked, the charging connector unlocks, but if the charging cable is not disconnected within 10 seconds, the connector will be automatically locked again
- If the charging connector is unlocked but all the doors are locked again, immediately, the connector will be automatically locked again
- If charging does not work, disconnect the connector and try charging again

REMINDER: If the connector cannot be unlocked, refer to section H4 in the Owner's Manual on how to unlock the connector in an emergency.

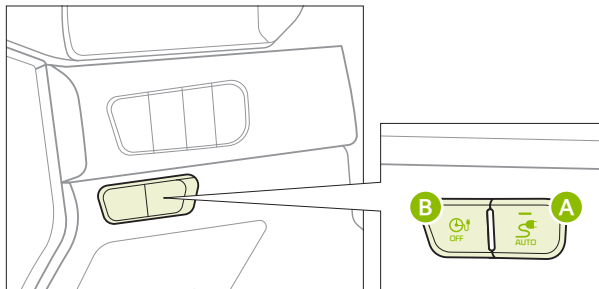

(Buttons are located left of the Steering Wheel)

Scheduled Charging*

Charging times can be set using UVO link with Navigation* system screen. You can also use the Scheduled Charging* feature on the Kia Access with UVO link app.

Charging with the Kia Access with UVO link app:

The Kia Access with UVO link app can help you find the nearest charging station, and also displays charging status and Scheduled Charging information. On your smartphone, go to an app store or marketplace to download the Kia Access with UVO link app.

REMINDER: When Scheduled Charging is set and the charger is plugged in, charging of the electric vehicle will not begin until the time and date set.

Deactivate Scheduled Charging - Depress the Deactivate Scheduled Charging button **B** to temporarily disable the scheduled charging feature when immediate charging is required.

QUICK TIP

When you press the Deactivate Scheduled Charging button the reserved charging setting will temporarily disable, and start immediate charging mode. If you need to completely deactivate the scheduled charge setting, change the setting from the audio control unit, or the smartphone Kia Access with UVO link app.

REMINDEES:

- For more detail and/or subsequent steps in charging your vehicle, including safety precautions that should be taken, please see the Owner's Manual
- Reserved charging may not be available at public chargers

QR CODE

Niro EV Charging
- Connecting &
Disconnecting Video



Refer to the inside front cover for more information on QR codes.
www.youtube.com/KiaFeatureVideos

Charging Your Electric Vehicle

Level 1 Charging - "Trickle" Charge

A Level 1 or "trickle" charger is the most common type of charging system for an electric vehicle. This type of charger uses 120 volts/12 amps of household electricity and takes approximately 60 hours for a full charge.

Trickle Charger Indicators:

- A** 120VAC plug
- B** Power - Indicates that the charger and AC plug is plugged in and functioning
- C** Charge - Indicates that the vehicle is charging
- D** Fault - Indicates charge failure
- E** Charge Level - Indicates the level of charge - L (8A), M (10A), or H (12A)
- F** ICCB - In-Cable Control Box

REMINDER: Do not use an extension cord. Plug trickle charger directly into wall socket. Do not charge to a receptacle that is not a dedicated circuit, old, damaged, corroded or cracked. When using outdoors, be careful not to expose it to external environments such as rain, snow, and high temperatures.

Level 2 Charging - "Normal" Charge (AC)

A Level 2 or "normal" 240-volt/32-amp charger is the recommended charging system for your electric vehicle. This type of charger uses 240 volts of electricity and takes approximately 9.6 hours for a full charge. This charger may be able to be installed at your home by a qualified electrician or can be found at a public charging station.

REMINDER: Shape of charger and how to use the charger may be different for each manufacturer. Please see Owner's Manual for more information.

Level 3 Charging* - "Quick" Charge (DC)

A Level 3 or "quick" DC charger is usually found at public charging stations. This type of DC charge may charge an electric vehicle in as little as 60 minutes to about an 80% charge.

REMINDER: Kia does not recommend primarily charging with a DC Charger because it can reduce the lifespan of the battery.

QR CODE

Niro EV Charging
- Connecting &
Disconnecting Video



Refer to the inside front cover for more information on QR codes.
www.youtube.com/KiaFeatureVideos

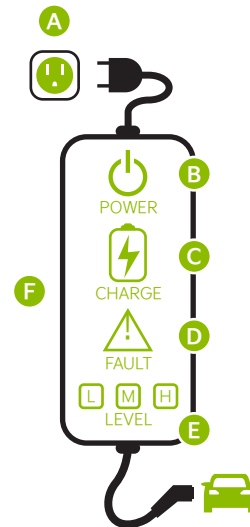

QUICK TIP

A Level 2 or "normal" 240-volt/32-amp charger is recommended for regular charging of the vehicle.

REMINDER: For more detail and/or subsequent steps in charging your vehicle, including safety precautions that should be taken, please see the Owner's Manual.

For more information on Level 3 Charging, refer to the Owner's Manual.

Charging Your Electric Vehicle (Continued)

To charge the Niro EV using a normal/trickle charger:

- Connect the ICCB or “Normal” Charger plug **A** to a dedicated 240-volt/32-amp electrical outlet
- Check if the power light (green) **B** on the ICCB turns on (trickle charger only)
- Press the brake pedal and engage the parking brake
- Turn off all switches, turn the Rotary Dial Shifter Knob to P (Park), and turn off the vehicle
- To open the charge port door, press the opening indicator (small triangle) at the far right edge of the charge port door **G**. Remove the inlet cover with tether **H** (the charging door can be opened when the vehicle is unlocked)
- Hold the charging connector handle and connect it to the vehicle’s trickle/normal charging inlet **I** by pushing the connector until you hear a clicking sound
- Charging begins automatically (Ensure the charge indicator light **S** is illuminated red on your instrument cluster, indicating the vehicle is charging, and ensure scheduled charging is not set)

Checking the Charging Status

The charging status can be checked by viewing the charging status indicator **J** on the dash panel. The lights will progressively become lit as the vehicle approaches a full charge. Ensure scheduled charging is not set.

REMINDER: For more detail and/or subsequent steps in charging your vehicle, including safety precautions that should be taken, please see the Owner’s Manual.

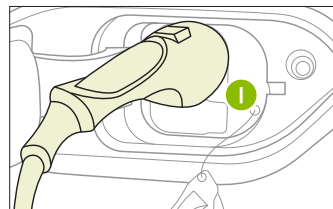
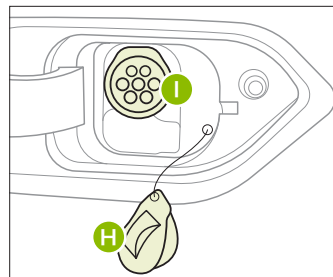
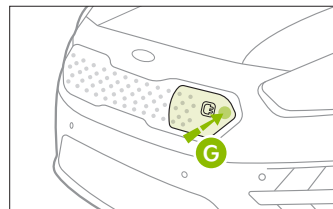

(Trickle / normal charge shown)

EV Mode - UVO link with Navigation*

EV Mode on the UVO link with Navigation system screen allows you to navigate to a total of five menus that include information on available driving range, energy usage, energy information, ECO driving, charging and climate settings, and EV settings.

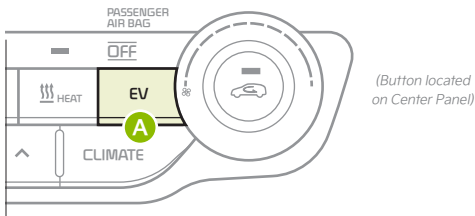

EV Button - Press the EV button **A** on the Climate Control panel to access the EV Mode screen or press the EV Mode button* on the touchscreen.

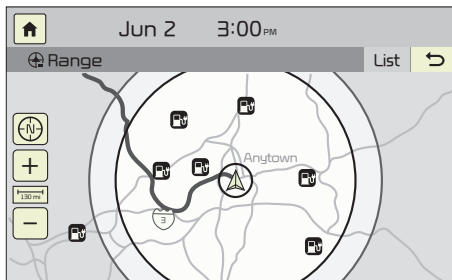

Available Range - Displays the available driving distance according to the vehicle's current location and charge amount. The projected available driving distance is marked in red on the map.

The estimated range is based on a number of factors and assumes optimal driving conditions, efficient driving habits and a straight road. Actual range will vary with options, driving conditions, driving habits, vehicle maintenance, charging practice, battery age, weather, temperature and your vehicle's condition. Battery capacity will decrease with time and use. For more information on range, please see www.fueleconomy.gov.

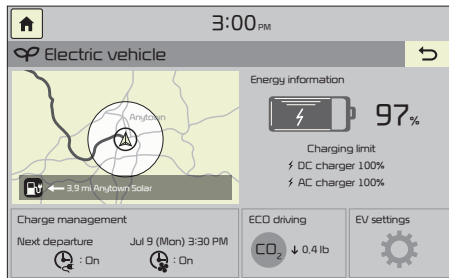

EV Mode menu - The EV Mode menu allows you to access five EV menus including Available Range, Energy information, ECO driving, Charge management and EV settings.

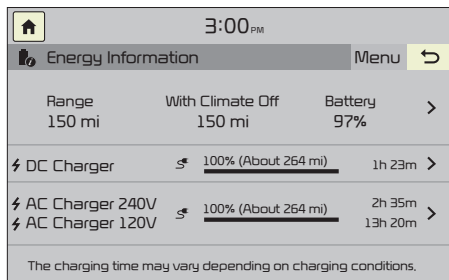

Energy Information - Displays battery charge information and electrical power consumption.

See Owner's Manual for more detailed information on screens.

These illustrations are for demonstration purposes only.

Some items may appear different or vary in illustrations.

EV Mode - UVO link with Navigation* (Continued)

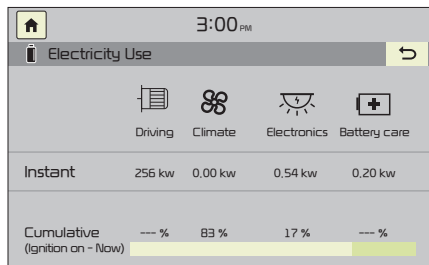

Electricity Use - Displays current energy consumption for each system of the vehicle.

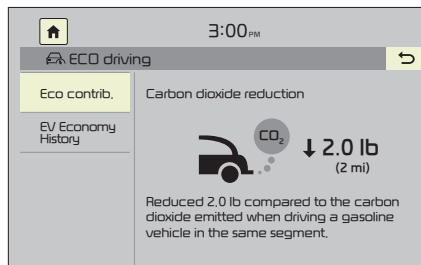

ECO Driving - Displays ECO level information and ECO driving history.

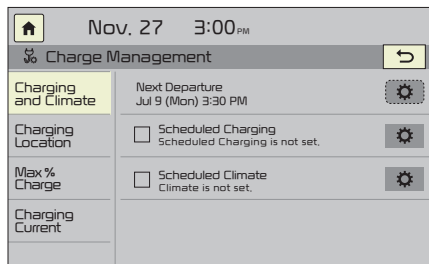

Charge Management - Allows you to select the time and date you wish to reserve for automatic charging and automatic climate control.

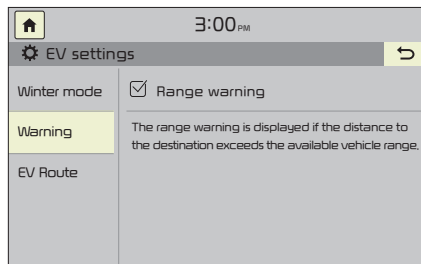

EV Settings - Allows the user to change the Winter mode, warning and EV Route settings.

See Owner's Manual for more detailed information on screens.

These illustrations are for demonstration purposes only. Some items may appear different or vary in illustrations.

Regenerative Braking with Paddle Shifters

The regenerative braking system charges the battery when coasting or when you use the brakes to stop the vehicle. Use the paddle shifters to adjust the regenerative braking level from 0 to 3 during decelerating or braking. The level will be displayed on the instrument cluster **A**.

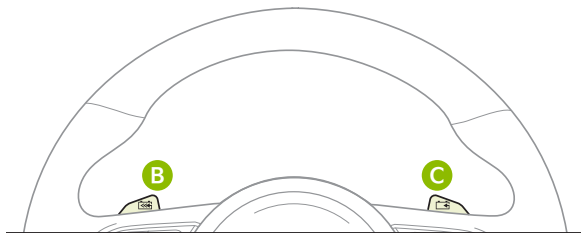

- Pull the left paddle shifter **B** to increase regenerative braking and deceleration
- Pull the right paddle shifter **C** to decrease regenerative braking and deceleration

The paddle shifters do not operate when:

- Both paddle shifters are pulled at the same time
- The vehicle is decelerating by depressing the brake pedal
- Cruise Control or Smart Cruise Control (SCC) is active

For more information on regenerative braking, one-pedal driving or the Smart Regeneration System, please refer to your Owner's Manual.

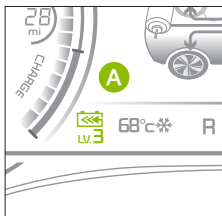

Brake and Hold System

The Brake and Hold System (one-pedal driving) increases the regenerative braking amount to above level 3 and enables you to come to a full stop by pulling down the left paddle.

- Pull and hold the left paddle shifter **B** while coasting
- When the vehicle speed is above 1.9 mph, release the left paddle shifter **B** for less than 0.5 seconds to return to the previously set level of regenerative braking
- When the vehicle speed is below 1.9 mph, the brake and hold system stops the vehicle even though the left paddle shifter is released
- While one-pedal driving is active, the driver can stop the vehicle by pulling the paddle shifter

REMINDER: The driver's seat belt must be fastened to operate one-pedal driving.

Do not solely rely on one-pedal driving to stop the vehicle, as it may not be able to stop the vehicle depending on vehicle and road conditions. Pay attention to the road condition ahead and apply the brake if necessary.

Smart Regeneration System

This system automatically adjusts the regenerative braking level based on a vehicle being detected in front of the Niro EV.

- Activate Smart Regeneration in the User Settings mode. AUTO **D** will be displayed on the instrument cluster. AUTO regenerative brake adjusts regenerative braking based on the distance with the vehicle in front and its speed
- Pull and hold the right paddle shifter **C** for more than 1 second to turn on/off the automatic change of the regenerative braking. The minimum regenerative braking level can be adjusted when in AUTO mode by using the left and right paddle shifters

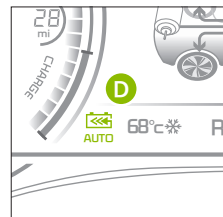

Smart Regeneration is a supplemental system for the driver's convenience. Do not solely rely on this system to stop the vehicle or avoid collisions. Always cautiously look ahead to prevent unexpected or sudden situations.

Blind-Spot Collision Warning (BCW)*†4

The BCW system uses radar sensors to help alert the driver if it detects an approaching vehicle in the driver's blind spot before changing lanes. The light on the BCW button **A** will illuminate when turned ON. The outside rearview mirror warning lights will also illuminate for 3 seconds.

The system will become active when the vehicle is traveling more than approximately 20 mph and will alert the driver if another vehicle is detected by the radar sensor.

1st-stage alert: When another vehicle is detected within the BCW boundary **B**, or when a vehicle is detected within the Lane Change Assist (LCA) boundary **C**, a yellow indicator will illuminate on the outside rearview mirrors.

2nd-stage alert: When 1st-stage alert is on and the driver activates a turn signal, a flashing yellow indicator will illuminate on the outside rearview mirrors and the system will sound an alert.

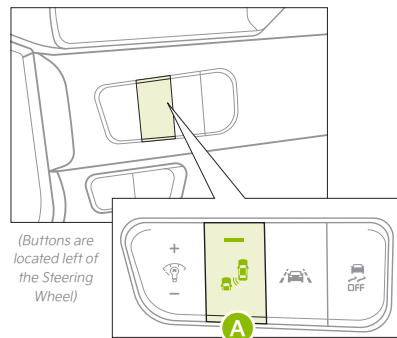

Rear Cross-Traffic Collision Warning (RCCW)*†4

If the RCCW system sensors detect approaching vehicles from the left or right side **D**, the system will sound an audible alert, the warning indicators on the outside rearview mirror will illuminate, and a message will appear on the LCD screen, if the following conditions are met:

- When Rotary Dial Shifter Knob is in Reverse
- When the vehicle is moving slower than 6 mph
- When the vehicle moves in reverse from a parked position

REMINDERS:

- If the BCW is turned ON/OFF and the ignition is cycled, the BCW system returns to ON/OFF
- The RCCW feature can be turned OFF/ON in User Settings
- The BCA and RCCW Warning Volume can be adjusted in the Vehicle Settings on the audio head unit. Adjusting this volume setting may also change other Driver Assistance systems' volume setting

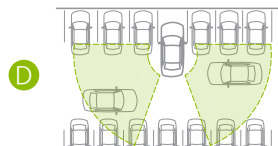
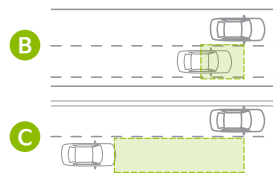

REMINDER: The above images are for illustration purposes only and may not reflect actual operation.

QR CODE

Blind-Spot Collision Warning with Lane Change Assist Video



Refer to the inside front cover for more information on QR codes.
www.youtube.com/KiaFeatureVideos

The BCW and RCCW systems are supplemental systems. Do not rely solely on these systems and always drive safely.

Refer to section 4/5 in the Owner's Manual for more information.

Lane Keeping Assist (LKA)*†4

Lane Keeping Assist (LKA) is designed to detect the lane markers on the road with a front view camera on the windshield, and may assist the driver's steering to potentially help keep the vehicle in the lane. The instrument cluster indicator will initially illuminate white when turned on. It will remain white when the vehicle is traveling slower than 40 mph or when the system does not detect the lane markers. When the system detects the lane markers and can assist the steering, the LKA icon will illuminate green.

If LKA detects that you are moving outside of your lane, the system may give an audible warning and display a Lane Departure Warning on the instrument cluster. If the vehicle continues to move outside of the lane, LKA may provide steering inputs, trying to prevent the vehicle from moving outside its lane.

LKA is the operating mode by default when the Lane Safety/LKA button* **A** is depressed to ON.

There are three available modes:

Active LKA - Provides more frequent steering inputs than standard LKA

Lane Keeping Assist - Guides driver to keep vehicle within lanes and provides steering inputs when vehicle is about to deviate from the lane

Lane Departure Warning - Alerts driver when the system detects the vehicle leaving the lane. In this mode the system will not provide steering inputs

LKA will operate under the following conditions:

- The vehicle speed exceeds approximately 40 mph
- The LKA system recognizes both sides of the lane markers the vehicle is traveling in
- The vehicle is between the lane markers

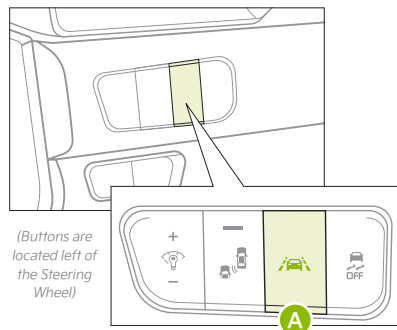

QR CODE

Lane Keeping Assist Video



Refer to the inside front cover for more information on QR codes.
www.youtube.com/KiaFeatureVideos

Lane Keeping Assist and Lane Departure Warning are not substitutes for safe driving and may not always alert the driver if the vehicle is driven outside of its lane. Always drive safely and use caution.

Actual User Settings steps may vary by model.

For illustrative purposes only. Your actual display, buttons and/or features may vary.

Refer to section 4 in the Owner's Manual for more information.



When the front-view camera detects the lane traveled in, both lanes are illuminated



When the front-view camera does not detect the lane traveled in the lanes are not illuminated









When the front-view camera detects the vehicle moving outside of the lane being traveled in, a yellow indicator will illuminate either on the left or right lane (shown in both images above)



Lane Keeping Assist (LKA)^{*†4} (continued)

LKA User Settings:

- To turn LKA ON, with the ignition on or the Engine Start/Stop button* in the ON position, press the Lane Safety/LKA button* **A**. The instrument cluster indicator  will initially illuminate white indicating the system is on
- To turn LKA on in the user settings, go to the User Settings menu  in the Instrument Cluster, press the Mode button  **B** on the Steering Wheel when the vehicle is at a standstill, gear shift is in Park and with the ignition on or the Engine Start/Stop button* in the ON position, and select User Settings 
- To switch between LKA modes (Lane Keeping Assist, Lane Departure Warning, Off), go to User Settings  in the Instrument Cluster. Press the Move (OK) button  **C** up/down, select desired setting and press the OK button  **C**



(Buttons are located left of the Steering Wheel)

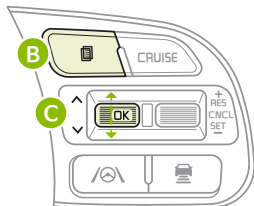

(Buttons located on Steering Wheel - Type B)

QUICK TIP

The LKA Warning Volume can be adjusted in the User Settings  in the Instrument Cluster or the Vehicle Settings* on the audio head unit.

REMINDERS:

- LKA will not issue a warning if the turn signals or hazard lights are activated
- When the ignition is cycled, LKA will return to the previously set state
- Some models access settings through the Vehicle Settings in the audio head unit. Press the Setup hard key on the audio head unit, then **VEHICLE**  on the screen to enter Vehicle Settings

Lane Following Assist (LFA)*†4

Lane Following Assist (LFA) is designed to help ensure that the vehicle stays centered in its lane **A** by monitoring the detected lane markings ahead and adjusting the steering. The instrument cluster indicator will initially illuminate white **A** when turned ON, and on some vehicles, when SCC is engaged. It will remain white when the system does not detect the lane markers. When the system detects the lane markers and can assist the steering, the LFA icon will illuminate green **B**. When LFA is enabled in the User or Vehicle Settings*, press the LFA button **C** to turn LFA on or off.

LFA will operate only when these conditions are met:

- LFA recognizes both sides of the lane markers the vehicle is traveling in
- The vehicle is traveling slower than 95 mph

LFA User Settings:

- To go to User Settings **G** in the Instrument Cluster, press the Mode button **D** on the Steering Wheel when the vehicle is at a standstill, gear shift is in Park and with the ignition on or the Engine Start/Stop button* in the ON position, and select User Settings **G**
- To enable LFA, when in User Settings, press the Move (OK) button **E** up/down and Select Driver Assistance then Driving Assist and select Lane Following Assist. Press the OK button **E**
- Some models access settings through the Vehicle Settings in the audio head unit. Press the SETUP hard key on the audio head unit, then **VEHICLE** **F** on the screen to enter Vehicle Settings
- Some vehicles have a Lane Driving Assist / Lane Safety button* on the Driver's Panel or the Steering Wheel **/**. Press to activate Lane Following Assist

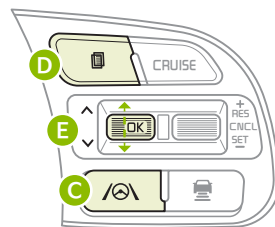
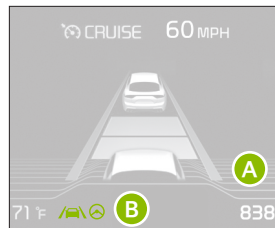

(Buttons located on steering wheel)

QR CODE

Lane Following Assist (LFA) Video



Refer to the inside front cover for more information on QR codes.
www.youtube.com/KiaFeatureVideos

Images are for illustrative purposes only and may not reflect actual feature or operation.

LFA is supplemental. Do not solely rely on this system and always pay attention to the road and its conditions.

Actual User Settings steps may vary by model. See section 5 in the Owner's Manual for more detailed information, limitations and conditions.

Lane Following Assist (LFA) is not a substitute for safe and proper driving. Always drive safely and use caution. LFA may not always alert the driver when the vehicle is approaching another vehicle.*

QUICK TIP

The LFA Warning Volume can be adjusted in the User Settings in the Instrument Cluster or the Vehicle Settings* on the audio head unit.

REMINDERS:





- If the ignition is cycled, LFA returns to its previous state, on or off, if activated in the User Settings menu **G** and when combined with SCC. If using the Steering Wheel LFA button, then LFA defaults to off
- LFA is not a substitute for safe and proper driving. Always drive safely and use caution

Forward Collision-Avoidance Assist (FCA)^{†4}

FCA is designed to detect and monitor a vehicle ahead or detect a pedestrian in the roadway through front view camera recognition and front radar signals to warn the driver that a collision is imminent, and if necessary, temporarily apply emergency braking. Initially, FCA provides Forward Collision Warning (FCW) when it detects a potential collision with a vehicle, pedestrian, or cyclist, emitting an audible warning and visual alert on the instrument cluster **A**.

If the system detects that the collision risk has increased, Forward Collision-Avoidance Assist (FCA) automatically applies the brakes to reduce your speed, potentially helping to reduce the effects of a possible collision.

FCA User Settings:

- FCA is ON by default in most Kia models. FCA can be turned ON/OFF by going to the User Settings in the Instrument Cluster
- To go to User Settings , press the Mode button  **B** on the Steering Wheel when the vehicle is at a standstill, gear shift is in Park and with the ignition on or the Engine Start/Stop button* in the ON position
- Press the OK button  **C** up/down and select User Settings  then Driver Assistance
 - In some models, go to Driving Assist, then Forward Collision-Avoidance Assist or Forward Collision Warning and press the OK button 
 - In other models, go to Forward Safety and select Active Assist, Warning Only or Off

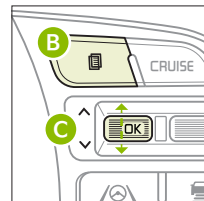

(Buttons located on steering wheel)

Then select one of the following modes:

- Active Assist:** Vehicle will provide a warning (audible & visual) and may apply the brakes if needed
- Warning Only:** Vehicle will provide a warning only (audible & visual)
- Off:** System is off, no warnings or braking provided
- To adjust the FCA initial warning activation time, go to User Settings , Driver Assistance, Warning Timing then select Fast, Normal or Slow, depending on your Kia model:
 - Fast:** When this condition is selected, the initial Forward Collision Warning is activated earlier than normal
 - Normal:** This setting allows for a nominal amount of distance between the vehicles before the initial warning occurs
 - Slow:** Reduces the amount of distance between the vehicles before the initial warning occurs

FCA/FCW will become active when the:

- Ignition is on or the Engine Start/Stop button* is ON
- Vehicle is traveling faster than 5 mph
- Electronic Stability Control (ESC) is ON

Forward Collision-Avoidance Assist (FCA) is not a substitute for safe driving and may not detect all objects in front of the vehicle. Always drive safely and use caution. Actual User Settings steps may vary by model. Refer to section 4 in the Owner's Manual for more information.

For illustrative purposes only. Your actual display, buttons and/or features may vary.

QR CODE

Forward Collision-Avoidance Assist Video



Refer to the inside front cover for more information on QR codes.
www.youtube.com/KiaFeatureVideos

QUICK TIP

FCA Warning Volume can be adjusted in the User Settings  in the Instrument Cluster or the Vehicle Settings* on the audio head unit. Go to Driver Assistance, then Warning Volume.

REMINDERS:

- FCA will be activated by default when the ignition is cycled ON, even when previous setting was OFF
- If FCA is operating and the ESC (Electronic Stability Control) is turned off, FCA system is automatically turned off
- When the FCA system is off, the FCA warning indicator is on in the Instrument Cluster 

Highway Driving Assist (HDA)*†4

Highway Driving Assist (HDA) is designed to adjust the speed of the vehicle when driving on limited/controlled access highways/freeways. The system can adjust the vehicle's speed based on available highway speed information. The automatic speed setting mode is designed to set the speed automatically by adjusting to the current speed limits of the highway the vehicle is traveling on.





To activate HDA, turn Smart Cruise Control (SCC) on by pressing the Driving Assist CRUISE / Driving Assist Mode  button* **A** on the Steering Wheel. When HDA is activated and the conditions are met, the Instrument Cluster indicator **B** will illuminate green. If proper conditions are not met, HDA will be in standby mode and the indicator light **B** will illuminate white. When in operation, and if both lanes are recognized, the Instrument Cluster will show the lanes illuminated white and the HDA indicator illuminated green **B**.

If HDA is activated, conditions are met and the SCC speed is set by the driver (at the posted highway speed limit or slower), HDA will enter the automatic speed setting mode. The set speed and AUTO will be displayed **C** in green and an audible alert will sound.

HDA will operate only when these conditions are met:

- The vehicle is traveling slower than 110 mph or the highway speed limit
- When driving on limited/controlled access highways/freeways
- When the SCC is on and operating
- When the SCC speed is set to current posted highway speed or slower

HDA User Settings:

To enable HDA, press the Mode button  **D** on the Steering Wheel and go to User Settings  in the Instrument Cluster. Press the Move (OK) button  up/down and press to Driver Assistance, then Driving Assist, Highway Driving Assist. Then press the OK button  to enable.

Some models access settings through the Vehicle Settings in the audio head unit. Press the Setup hard key on the audio head unit, then press Vehicle  on the screen to enter Vehicle Settings.

REMINDERS:

- Current highway speeds and controlled or limited access road information may vary. Future navigation updates may change this information
- If the driver changes the speed while in automatic speed setting mode, it deactivates and enters a manual mode
- When the ignition is cycled, the system returns to its previous state, on or off

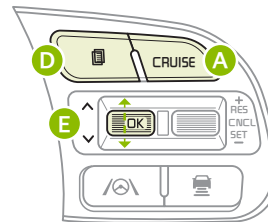

(Buttons located on steering wheel)

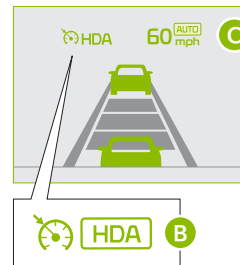

QR CODE

Highway Driving Assist (HDA) Video



Refer to the inside front cover for more information on QR codes.
www.youtube.com/KiaFeatureVideos



Highway Driving Assist is not a substitute for safe driving, may not detect all objects around the vehicle, and only functions on certain federal highways. Always drive safely and use caution.

See section 5 in the Owner's Manual for more detailed information, limitations and conditions.

Leading Vehicle Departure Alert (LVDA)^{†4}

Leading Vehicle Departure Alert is designed to inform the driver when the vehicle in front starts moving or departs from a stop. When LVDA is on, your vehicle is stopped and detects that the leading vehicle is driving away, LVDA sounds an alert to let you know you can start driving. If no action is taken after the vehicle in front drives away, then a message **A** will appear on the Instrument Cluster LCD.

LVDA User Settings:

- To turn LVDA on, press the Mode  button **B** on the Steering Wheel, and go to User Settings  in the Instrument Cluster. Press the Move (OK) button **C** up/down and select Driver Assistance, then press the OK button **C** to select. Go to Driver Attention Warning and then Leading Vehicle Departure Alert
- Some models access settings through the Vehicle Settings in the audio head unit. Press the Setup hard key on the audio head unit, then press **VEHICLE**  on the screen to enter Vehicle Settings

To adjust the LVDA initial warning activation time, go to User Settings, Driver Assistance, Warning Timing then select Normal, or Late, depending on your Kia model:

- **Normal:** This setting allows for a nominal amount of distance between the vehicles before the initial warning occurs
- **Late:** Reduces the amount of distance between the vehicles before the initial warning occurs

REMINDERS:

- When the ignition is cycled, the system returns to its previous state, on or off
- Always check the front of the vehicle and road conditions before departure

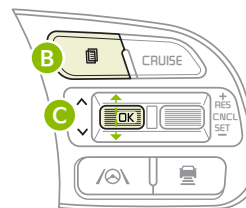

(Buttons located on steering wheel)

QR CODE

Leading Vehicle Departure Alert (LVDA) Video



Refer to the inside front cover for more information on QR codes.
www.youtube.com/KiaFeatureVideos

The Leading Vehicle Departure Alert system is not a substitute for safe and proper driving. Always drive safely and use caution.

Images are for illustrative purposes only and may not reflect actual feature or operation.

Smart Cruise Control (SCC) with Stop & Go*†‡4

The Smart Cruise Control with Stop & Go* system is designed to maintain a predetermined distance from vehicles detected ahead by automatically adjusting the driving speed as needed. When traffic is detected, the vehicle will automatically slow to maintain a set distance between traffic without depressing the accelerator or brake pedal.

When SCC is on and activated, the vehicle distance set, and the system detects a vehicle slowing or stopping, the system can bring the vehicle to a complete stop. When the vehicle ahead starts to move forward, the SCC system re-engages. If the vehicle ahead stops for more than 3 seconds, the accelerator pedal or the RES+ button must be pressed to start moving the vehicle.

On some models, press the Driving Assist Mode  CRUISE button* on the Steering Wheel to activate and the speed will be set to the current vehicle speed. SCC may decrease the speed to maintain the distance with the vehicle in front.

To set/adjust the SCC speed:

- Push the Driving Assist Mode CRUISE / Driving Assist Mode  CRUISE button* **A** to turn the system ON & set the current speed (One-Touch Set). The cruise indicator will illuminate on the instrument cluster
- Accelerate/decelerate to the desired speed and press lever **B** down to set the speed
- Press the RES+/SET- (+/-) button* **B** up/down to increase/decrease the set speed
- The SET indicator light, set speed and vehicle distance will illuminate on the instrument cluster's LCD screen **C**

To set the vehicle distance: Press the Vehicle Distance button **D** on the steering wheel. The image on the LCD screen **C** will change when scrolling through the settings. Each time the button is pressed, the vehicle distance changes.

To cancel or pause SCC operation: Press the CANCEL* or pause  button* **B**. The cruise indicator on the instrument cluster will turn OFF.

To turn SCC OFF: Press the CRUISE button **A**. The cruise indicator on the instrument cluster will turn OFF.

To adjust the sensitivity of the SCC system: Press the mode button  **E** on the Steering Wheel. With the OK button **F**, select Driver Assistance, then SCC Response. Then select Fast, Normal or Slow.

The SCC system is a supplemental system and is not a substitute for safe driving. It is the responsibility of the driver to always check the speed and distance to the vehicle ahead.

See section 5 in the Owner's Manual for more information. Images are for illustrative purposes only and may not reflect actual feature or operation.

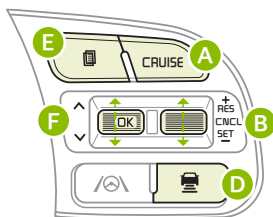

(Type B Steering Wheel shown; buttons located on right side of Steering Wheel)

C 172ft → 130ft → 106ft

82ft ←

The distance settings are approximations and may vary depending on the vehicle speed at the time.

CRUISE 60 MPH



Smart Cruise Control Mode



Cruise Control Mode



QR CODE

Smart Cruise Control with Stop & Go Video



Refer to the inside front cover for more information on QR codes.
www.youtube.com/KiaFeatureVideos

Smart Cruise Control (SCC) with Stop & Go*⁺⁴ (Continued)

QUICK TIPS

- The speed setting for SCC can be adjusted under the following conditions:
- You must be travelling at a minimum speed of 5 mph (may vary on newer models)
- When following a vehicle, there is no minimum speed requirement
- When following a vehicle, the system can automatically adjust your cruise speed based on the vehicle detected ahead. If the vehicle detected ahead remains at a standstill and your vehicle is also stopped for longer than 3 seconds, the system will need to be reactivated by pressing the accelerator or pressing the RES button

REMINDERS:

- The cruise control system will not activate until the brake pedal has been depressed at least once after the ignition is ON or engine starts
- When following a vehicle, the system will automatically adjust your cruise speed based on the vehicle detected in front
- SCC is also canceled when the driver's door is opened, gear shift is changed out of D (Drive), EPB is activated and various other conditions. See the Owner's Manual for other conditions
- If SCC is left on, it can be activated inadvertently. Keep the system off when not in use to avoid setting a speed which the driver is not aware of

Navigation-based Smart Cruise Control (NSCC)⁺⁴

Navigation-based Smart Cruise Control can automatically adjust the vehicle speed when it detects a curved road ahead and when it receives road information from the navigation system.

To turn on NSCC, go to the User Settings in the instrument cluster or the Vehicle Settings* in the audio head unit, by selecting Driving Convenience, Highway Auto Speed Change. When SCC is on and operating, the vehicle is driving on limited/controlled access highways and NSCC is turned on, then NSCC is enabled and the AUTO icon **A** will illuminate white on the Instrument Cluster.

When NSCC detects a curve ahead, NSCC activates and reduces the vehicle speed, the AUTO icon **A** will turn green. When the vehicle passes the curved road, the vehicle may return to its previously set SCC speed.

Autoset (Automatic change of set speed): If the set speed is set to the current speed limit on the highway during NSCC operation, the set speed is changed automatically whenever the speed limit changes.

REMINDERS:

- NSCC requires an active navigation subscription
- NSCC is only available on controlled access roads and highways

See section 5 in the Owner's Manual for more information. For more setting information, refer to the Car Infotainment System Quick Reference Guide. NSCC and Cruise Control are supplemental systems and are not substitutes for safe driving. It is the responsibility of the driver to always check the speed and distance to the vehicle ahead.

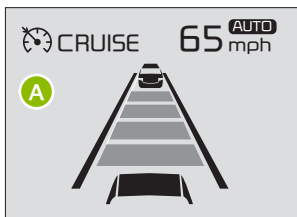

(Display on LCD screen)

Cruise Control⁺⁴

B CRUISE Control ON/OFF button - Press to turn the Cruise Control ON/OFF

C Cruising Speed button:

- Press up to resume or increase Cruising Speed
- Press down to set or decrease Cruising Speed
- Cruise Control CNCL button - To cancel Cruise Control setting, do one of the following:
 - Press the brake pedal
 - Press the CNCL button

QUICK TIPS

- Cruise Control is designed to function above 20 mph
- The Cruise Control system will not activate until the brake pedal has been depressed at least once after ignition ON or engine start

See section 5 in the Owner's Manual for more information.

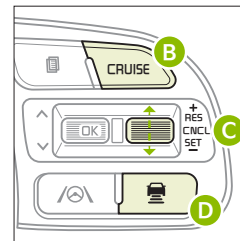

Driver Attention Warning (DAW)*†5

Driver Attention Warning is designed to alert the driver if it detects inattentive driving practices and, in certain situations, can give a warning signal to take a break from driving. There are three modes:

- **Normal Sensitivity:** Driver Attention Warning warns the driver of his/her inattentive driving practices
- **High Sensitivity:** Driver Attention Warning warns the driver of his/her inattentive driving practices faster than Normal mode
- **Off:** Driver Attention Warning is deactivated

If DAW is activated, the DAW information **A** will appear on the Instrument Cluster LCD when you select the Driving Assist/Assist mode menu in User Settings **⚙️**. A message, "Consider taking a break," **B** appears on the LCD and a warning sounds to suggest the driver take a break when the driver's attention level becomes low.

DAW User Settings:

To turn DAW on/off, with the ignition on, press the Mode button **C** on the Steering Wheel and go to User Settings **⚙️** in the Instrument Cluster. Then go to Driver Assistance and select Driver Attention Warning. Set DAW to Normal Sensitivity, High Sensitivity or Off.

- Some models access settings through the Vehicle Settings in the audio head unit. Press the Setup hard key on the audio head unit, then press **VEHICLE** **🚗** on the screen to enter Vehicle Settings

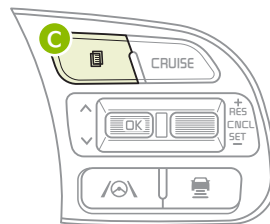

REMINDERS:

- The setup of DAW will be maintained, as selected, when the ignition is cycled
- When activated, DAW does not display "Consider taking a break" message when the total trip driving time is less than 10 minutes
- DAW will enter a standby mode if the camera does not detect the lanes and/or the driving speed remains under 40 mph

QR CODE

Driver Attention Warning (DAW) Video



Refer to the inside front cover for more information on QR codes.
www.youtube.com/KiaFeatureVideos

Driver Attention Warning is not a substitute for safe driving and may not detect all instances of inattentive driving practices. Failure to pay attention to travel conditions and vehicle operation could result in loss of vehicle control. Always drive safely and use caution.

Refer to section 5 in the Owner's Manual for more information.

Rear Occupant Alert (ROA) with Door Monitoring^{†9}

The Rear Occupant Alert (ROA) with Door Monitoring can help alert the driver when a rear passenger may be left in the vehicle. The alert will be a message on the Instrument Cluster stating to "Check rear seats"  and a chime will sound.

The factory default is set to OFF. To turn the system ON or OFF, go to User Settings in the Instrument cluster or Vehicle Settings* on the audio head unit, select Convenience, then Rear Occupant Alert and check/uncheck the box.

REMINDER: Always be sure to check the passenger areas before leaving the vehicle.

Rear Occupant Alert is not a substitute for one's attention and may not detect all movement within the vehicle. Always check the vehicle interior when exiting the vehicle.

See section 4 in the Owner's Manual for more information.

Image is for illustrative purposes only and may not reflect actual feature or operation.



QR CODE

Rear Occupant Alert (ROA) with Door Monitoring video



Refer to the inside front cover for more information on QR codes.
www.youtube.com/KiaFeatureVideos

ADAS

Reverse Parking Distance Warning (PDW)^{*†4}

Reverse Parking Distance Warning (PDW) is a supplemental system that is designed to warn the driver by chiming if any object is detected within the sensing area to the front and rear of the vehicle when moving forward or backing up.

PDW is activated when the ignition is ON/Ready and the vehicle is in R (Reverse). To deactivate PDW, press the PDW button **A** (LED illuminated), when vehicle is in D (Drive) or R (Reverse).

To activate, press button **A** again (LED not illuminated).

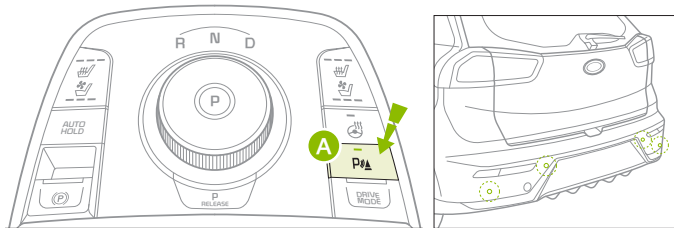

REMINDERS:

- If the vehicle is moving at speeds over 3 mph, the system may not activate correctly
- When more than two objects are sensed at the same time, the closest one will be recognized first
- The above images are for illustration purposes only. Operational details may vary
- Reverse Parking Distance Warning (PDW) is not a substitute for proper and safe parking and backing-up procedures. Always drive safely and use caution when backing up. Reverse Parking Distance Warning (PDW) may not detect every object in front of or behind the vehicle.

Refer to section 4 in the Owner's Manual for more information.

Rear View Monitor (RVM)^{†4}

Rear View Monitor is a supplemental system that displays the view behind the vehicle through the audio system screen while the vehicle is in Reverse.

The Rear View Monitor activates when the:

- POWER button is in the ON/READY position
- Rotary Dial Shifter Knob is in the R (Reverse) position

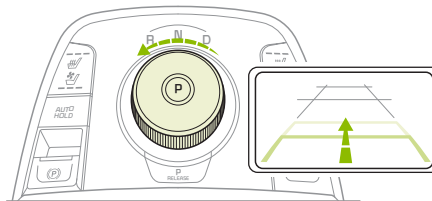

REMINDERS:

- The images shown are for illustration purposes only and may not reflect actual operation
- UVO link - While camera is active, only the audio controls on the Audio System can be operated
- UVO link with Navigation* - While camera is active, only the Audio System can be operated on the Steering Wheel and Audio Head Unit. All other features are disabled
- Rear View Monitor may not display every object behind the vehicle

Rear View Monitor is not a substitute for proper and safe backing-up procedures. Rear View Monitor may not display every object behind the vehicle. Always drive safely and use caution when backing up.

QR CODE

Forward/Reverse Parking Distance Warning (PDW) Video



Refer to the inside front cover for more information on QR codes.
www.youtube.com/KiaFeatureVideos

Refer to section 4 in the Owner's Manual for more information.

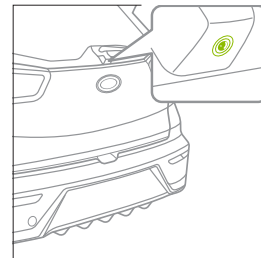

Instrument Cluster Control

Press switch **A** up or down to adjust display brightness of the instrument panel illumination.



(Buttons are located left of the Steering Wheel)

Electronic Stability Control (ESC)^{†6}

The ESC system is designed to help stabilize the vehicle during certain cornering maneuvers. It is a good idea to keep ESC turned ON whenever possible.

Press ESC OFF button **B** to disable Traction Control in ESC (ESC OFF indicator will illuminate).

To turn both Traction Control and Stability Control off, press and hold ESC OFF button **B** (ESC OFF indicator will illuminate, and an alert sounds).

REMINDERS:

- ESC is active by default at vehicle startup
- The ESC Indicator Light  in the instrument cluster will illuminate whenever the ESC is in operation

Refer to section 5 in the Owner's Manual for more information.

Hill-Start Assist Control (HAC)^{†6}

The HAC system is designed to help prevent the vehicle from rolling backward when accelerating from a stop while on a steep incline.

The HAC system automatically activates whether the ESC is OFF or ON but does NOT activate when the ESC has malfunctioned.

QUICK TIPS

- When HAC is active (e.g., accelerating from a stop on an incline), you may notice that the brakes will momentarily remain engaged after you depress the accelerator. This is normal HAC operation
- HAC provides a two-second delay before the vehicle may start rolling backward

REMINDERS:

- The HAC system does not operate when the Rotary Dial Shifter Knob is in the P (Park) or the N (Neutral) position
- In the event of an HAC system malfunction, see an Authorized Kia Dealer for service
- HAC does not replace the need to apply brakes while the vehicle is stopped on an incline

Refer to section 5 in the Owner's Manual for more information.

Power Button^{†10}

To start the vehicle:

1. Depress the brake pedal
2. Press the POWER button while Rotary Dial Shifter Knob is in P (Park) or (N) Neutral

To turn the vehicle power OFF, press the POWER button.

To use the POWER button, you must have the Smart Key fob on your person.

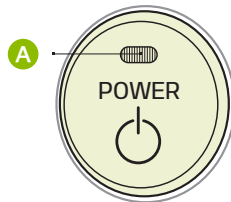

QUICK TIPS

To use electrical accessories:

- **ACC position**
 - When in the OFF position and without depressing the brake pedal, press the POWER button once (amber light **A**)
- **ON position**
 - When already in the ACC position (amber light **A**) and without depressing the brake pedal, press the POWER button again (red light **A**)
 - When in the OFF position (not illuminated) and without depressing the brake pedal, press the POWER button twice (red light **A**)

REMINDERS:

- In an emergency situation while the vehicle is in motion, you are able to turn the vehicle off and to the ACC position by pressing the POWER button for more than 2 seconds or 3 times successively within 3 seconds
- If the Smart Key battery is weak or not working properly, hold the Smart Key fob up to the POWER button (Lock button side closest) and press to start vehicle
- Do not turn the vehicle off by pushing the POWER button while the vehicle is in motion. If the vehicle has been turned off the power brake and power steering system cannot operate
- With the vehicle off, hydraulic power assist for steering and braking will be disabled and the vehicle will be more difficult to control

QR CODE

Kia Smart & Folding Key Fobs Video



Refer to the inside front cover for more information on QR codes.
www.youtube.com/KiaFeatureVideos

Refer to section 5 in the Owner's Manual for more information.

Power Windows, Window Lock & Central Door Lock

- A** Pull/Press to operate Driver's and Front Passenger's Windows Auto-Up/Down*

QUICK TIP

Press the button again to stop Auto Up/Down function.

- B** Press to Unlock/Lock All Doors
- C** Press to disable Rear Passenger Windows

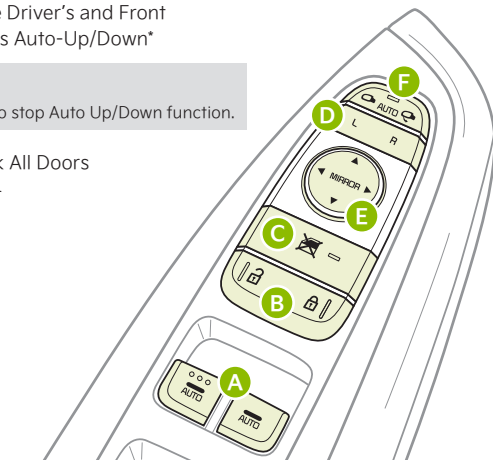

QUICK TIPS

- While driving with the rear windows down or with the sunroof* in an open or partially open position, a wind buffeting or pulsation noise may be heard. This noise is a normal occurrence and can be reduced or eliminated by the following:
 - If the noise occurs with one or both of the rear windows down, partially lower both front windows approximately 1 inch
 - If the noise occurs with the sunroof open, slightly reduce the size of the sunroof opening

REMINDERS:

- When pressed **C**, window controls for the Rear Passenger Windows are disabled
- When closing, be mindful of any objects or persons

Refer to section 4 in the Owner's Manual for more information.

Automatic Door Lock

Auto Door Lock will engage when the Rotary Dial Shifter Knob is moved into or out of the P (Park) position. Refer to the User Settings in the LCD Instrument Cluster modes on how to turn Auto Door Lock/Unlock ON/OFF.

Button configuration may vary depending on vehicle model. Refer to section 4 in the Owner's Manual for more information.

Power/Heated Outside Mirrors

Mirror heaters automatically turn ON/OFF at the same time the Rear Window Defroster is turned ON/OFF. Rear Window Defroster button* is located on climate control system panel.

Refer to section 4 in the Owner's Manual for more information.

Power Folding Outside Mirrors*

Press L or R buttons **D** (left or right) to select mirrors. Then press arrows **E** to adjust mirror position.

To fold and unfold both the outside rearview mirrors, press the folding mirror button **F** as pictured:

- **Left** – The mirrors will unfold
- **Right** – The mirrors will fold
- **Center** – The mirrors will fold/unfold automatically when doors are locked/unlocked with the Smart Key or a door handle button is pressed. Also, the mirrors will unfold when approaching the vehicle with the Smart Key fob in proximity

QUICK TIP

To automatically fold mirrors when exiting vehicle, press the LOCK button once on the Smart Key.

REMINDER: To lock position of mirrors, toggle switch to the neutral (center) position.

Refer to section 4 in the Owner's Manual for more information.

Headlights & High Beams

To operate:

- Rotate lever to change the Headlight function
- Push lever to turn High Beams ON
- Pull lever to flash Headlights/ High Beams

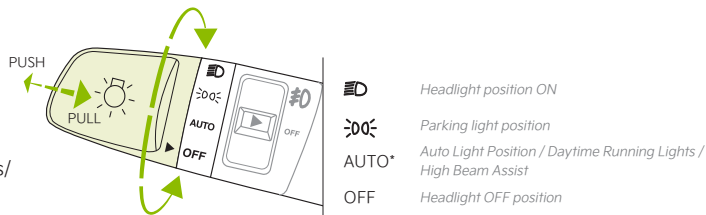

AUTO Light position - When the light switch is in the AUTO Light position, the tail lights and headlights will turn ON/OFF automatically depending on the amount of light outside the vehicle.

Daytime Running Lights (DRL) - DRL may help others to see the front of your vehicle during the day. The lights will be on automatically when the ignition or POWER button* is ON and the headlight switch is in the AUTO position, unless one of the following occurs:

- Parking brake is applied
- Engine is turned off

High Beam Assist (HBA) - The High Beam Assist is designed to automatically adjust the headlight range by switching between high and low beams based on light detected from oncoming vehicles and road conditions.

To enable HBA, toggle the light switch to the AUTO Light position and turn on the high beams by pushing the lever away from you. The High Beam Assist indicator will illuminate.

High Beam Assist does not operate below certain speeds, or in some lighting and driving conditions. Please be aware of your surroundings and exercise proper road etiquette when operating a vehicle using the high beams.

REMINDERS:

- HBA will operate when vehicle speed exceeds 25 mph
- If the lever is pushed away from you while HBA is operational, HBA will turn off and the high beams will be on continuously. If the lever is pulled toward you while HBA is operational, HBA will turn off
- If the light switch is switched to the headlight position, HBA will turn off and low beams will be on continuously
- The DRL system turns off when parking brake is applied
- DRL only operates during the daytime

Turn Signals & Fog Lights

To operate:

Turn Signals - Move lever Up/Down for Right/Left Turn Signal

Fog Lights - Press switch **A** to turn Fog Lights ON/OFF

REMINDER: Headlights must be in the ON/AUTO position for Fog Light operation.

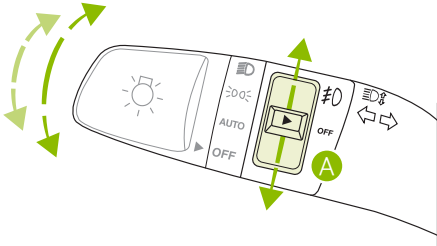

One-Touch Lane Change Signal is activated by briefly pressing the Turn Signal Lever slightly up or down for less than 1 second and then releasing. The lane change signal will blink 3-7 times.

To change how many times (3/5/7 times) the Lane Change Signal blinks, go to User Settings Mode in the LCD Instrument Cluster modes.

For illustrative purposes only. Your actual display, buttons and/or features may vary.

Refer to section 4 in the Owner's Manual for more information.

Tilt/Telescoping Steering Wheel†18

To adjust the Steering Wheel, push the lock-release lever **B** down and adjust the desired angle **C** and distance **D**.

When finished, pull the lock-release lever **B** up to lock Steering Wheel in place.

Do not attempt to adjust steering wheel position when vehicle is in motion as this may cause you to lose control of the vehicle.

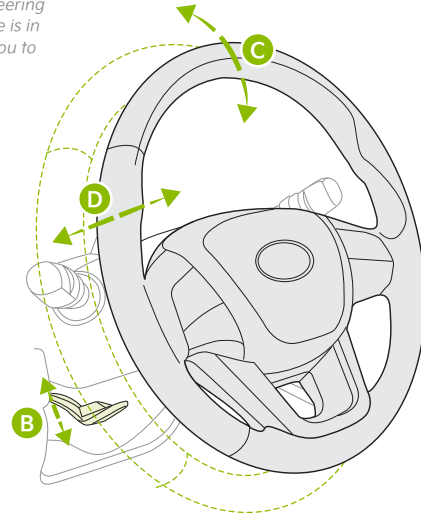

QUICK TIP

It may be helpful to pull/push bottom of Steering Wheel towards/away from you to adjust desired distance.

Refer to section 4 in the Owner's Manual for more information.

Windshield/Rear Wipers & Washers

To operate Windshield Wipers and Washers:

- Move lever Up/Down to change front Wiper modes
- Press switch **A** Up (fast) / Down (slow) to adjust Intermittent Wipe Speed
- Pull lever to spray and wipe front windshield
- Push lever to spray and wipe rear glass

WINDSHIELD
 MIST: Single wipe
 OFF: Wiper off
 INT: Intermittent wipe
 LO: Slow wipe
 HI: Fast wipe

REAR
 HI: Continuous wipe
 LO: Intermittent wipe
 OFF: Wiper off

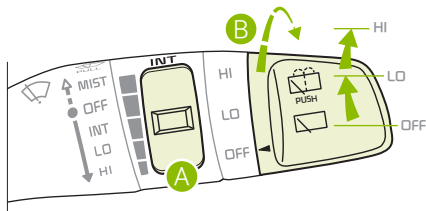

QUICK TIPS

- Pressing switch **A** up increases Intermittent wipe frequency and wipe speed. Pressing switch **A** down decreases frequency of wipes
- Set the wiper to OFF position when the wiper is not in use
- LO and HI sets rear wiper speed. Low intermittent wipe function on rear wipers
- On Rear Wipers, the intermittent wipe function only has one speed and is not adjustable

QR CODE

Wipers and Wiper Stalk Video



Refer to the inside front cover for more information on QR codes.
www.youtube.com/KiaFeatureVideos

Refer to section 4 in the Owner's Manual for more information.

To operate Rear Wiper & Washer:

- Rotate Rear Wiper switch **B**
 LO - Intermittent / HI - Continuous to change Wiper modes
- Push lever to spray and wipe

Audio Controls^{†15}

- A Audio MODE button:** Press to cycle through FM/AM/SiriusXM®/Media modes
- Audio System ON/OFF:** Press to turn power on; Press and hold to turn power off
- B Seek/Preset button:**
FM/AM/SiriusXM® Modes: Press up/down to advance through Preset Stations.
Press and hold to auto seek
- Media Mode:** Press up/down to move Track Up/Down. Press & hold up/down to fast forward/rewind (except for *Bluetooth*® Audio)
- C Volume button:** Press up/down to raise/lower volume
- Mute button:** Press to mute/unmute all audio (Media pauses in some Media modes when pressed)

QUICK TIP

Pressing the Audio Mode button for more than 1 second will turn Audio Mode ON/OFF (Standard Audio System - Value only).

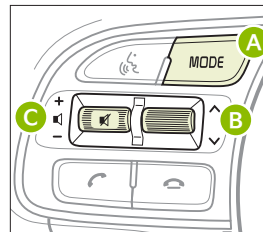

Driving while distracted is dangerous and should be avoided. Drivers should remain attentive to driving and always exercise caution when using the steering-wheel-mounted controls while driving. To help minimize driver distraction, some audio system functionalities have been modified while the vehicle is in Drive, Reverse or moved out of Park.

For further audio system operation, refer to pages 38-43.

Your vehicle's steering wheel buttons may differ from those in the illustrations. See the Owner's Manual or the Car Infotainment System Quick Reference Guide.

Bluetooth® Wireless Technology†3,15

- A Volume button:** Press up/down to raise/lower speaker volume
Mute button: Push to mute the microphone during a call
- B Talk button:** Press to activate voice recognition/bring up menus/
place calls with minimal voice command prompts from the system.
Press and hold to exit voice recognition
UVO link with Navigation system* - When enrolled with a UVO link
subscription, press this button to activate the UVO Voice Assist to use
navigation guidance and search destinations
- C Receive/Place Call button:** Press to receive/place calls. In vehicles
with navigation, if no phone is paired, press button to pair a phone
- D End Call button:** Press to end a call, reject an incoming call or cancel
a function

QUICK TIPS

- Phone book transfer upload time varies by phone model and with number of phone book entries
- When using the voice command feature, wait for the system BEEP before speaking the command
- Because of differences in phone quality, service providers and Bluetooth® Wireless Technology chip programming, functionality may differ from one phone to another
- The system may register or pair multiple Bluetooth® devices. See the Car Multimedia System User's Manual for more information on setup and limitations

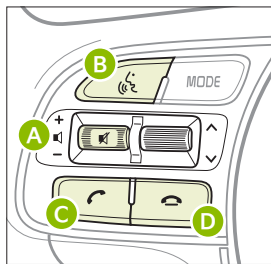

(Type B shown)

Pairing a Phone

For instructions on how to pair a phone, refer to the Car Multimedia System User's Manual or your vehicle's Quick Start Guide.

QUICK TIP

During the pairing process, be sure to accept the connection requests on the phone for contacts download and to allow acceptance of all future Bluetooth® connection requests.

How to Place a Call

- **Option 1:** Press the Receive/Place Call button **C** (displays the phone screen with call history)
- **Option 2:** Press the Talk button **B**. Then say the command "Call {name}" or "Dial {number}" followed by contact name or number

QUICK TIP

When using the voice command feature, wait for the system BEEP before speaking the command.

Bluetooth® wireless Technology audio and calling functions are supported when connected to a Bluetooth® enabled device (sold separately).

Your vehicle's steering wheel buttons may differ from those in the illustrations. See your Owner's Manual for more details.

Driving while distracted is dangerous and should be avoided. Drivers should remain attentive to driving and always exercise caution when using the steering-wheel-mounted controls while driving.

For more information, refer to the Car Infotainment System Quick Reference Guide. For Bluetooth® Wireless Technology FAQs, go to www.kia.com, Owners section, or call Consumer Information for Bluetooth® Technology at (800) 333-4KIA. Refer to your Owner's Manual for more specific Bluetooth® Wireless Technology phone pairing and operation instructions.

Bluetooth® Wireless Technology†3,15 (Continued)

Voice Recognition and Phone Contact Tips

The system may have difficulty understanding some accents or uncommon names. Improve the performance by making a few simple changes to your phone contacts, listed below. To help optimize the Bluetooth® Wireless Technology Voice Recognition system, see other tips and reminders under Quick Tips:

- Use full names (first and last names) vs. short or single-syllable names (e.g., "John Smith" vs. "Dad," "Smith Residence" vs. "Home")
- Avoid using special characters, emojis or hyphenated names (e.g., @, &, #, /, -, *, +, etc.)
- Avoid using acronyms (e.g., "In Case of Emergency" vs. "ICE") or words with all capital letters
- Spell words completely, no abbreviations (e.g., "Doctor Smith" vs. "Dr. Smith")

QUICK TIP

- **Bluetooth® Music Streaming** - If the Bluetooth® music is inaudible or too low, you may need to turn up the volume on the connected phone
- When placing a call, speak in a natural, moderate tone, with clear pronunciation. The system may have trouble recognizing commands if you speak too softly or too loudly
- Always wait for the beep before speaking any commands
- Close windows and turn off A/C - Open windows, weather (wind/rain), or an A/C fan operating at higher speeds can interfere with Voice Recognition
- Press the talk button and say "Help" to get a list of available commands
- The system may register or pair multiple Bluetooth® devices. See the Car Infotainment System Quick Reference Guide for more information on setup and limitations

QR CODE

Voice Recognition Tips Video



Refer to the inside front cover for more information on QR codes.
www.youtube.com/KiaFeatureVideos

Android Auto™ †3 / Apple CarPlay® †3 Setup

Android Auto™ compatible smartphone setup - Download the Android Auto™ app from the Google Play™ Store†11. Open the Android Auto™ app and proceed with the onscreen instructions to complete setup on the mobile device.

Cable Connection setup for Android Auto™:

1. Press the SETUP key on the audio head unit
2. Press DEVICE CONNECTION, select Android Auto™ and then select ENABLE ANDROID AUTO. Review all terms, conditions and requests on the head unit and phone, and, if you agree, accept them in order to use Android Auto™
3. Connect the Android™ device with the vehicle's USB port using the manufacturer's cable provided with your phone
4. From the vehicle's home screen, select the Android Auto™ button, where you'll see all the Android Auto™ supported apps

QUICK TIPS

- If Android Auto™ / Apple CarPlay® randomly disconnects:
 - Ensure the USB cable is certified by the phone manufacturer for both power and data
 - Clean the phone's port, which the USB cable connects to, as instructed by the phone's manufacturer.
 - The phone should not be disturbed while driving as this can cause a disconnection at the phone's USB port
 - Visit the phone manufacturer's website for Android Auto™ / Apple CarPlay® app concerns

Driving while distracted can result in a loss of vehicle control that may lead to an accident, severe bodily injury, and death. The driver's primary responsibility is in the safe and legal operation of a vehicle, and any handheld devices, other equipment, or vehicle systems which take the driver's eyes, attention and focus away from the safe operation of a vehicle or which are not permissible by law should never be used during operation of the vehicle.

Cable Connection setup for Apple CarPlay®:

1. Connect the Apple CarPlay® compatible iPhone® with the vehicle's USB port using the manufacturer's cable provided with your iPhone®
2. Press the SETUP key on the audio head unit
3. Press DEVICE CONNECTION on the screen and select Apple CarPlay®
4. Select ENABLE APPLE CARPLAY®. Review all terms, conditions and requests on the head unit and phone, and, if you agree, accept them in order to use Apple CarPlay®
5. From the audio head unit home screen, select the Apple CarPlay® button, where you'll see all the Apple CarPlay® supported apps

REMINDERS:

- Android Auto™ compatibility requirements for connection:
 - UVO link with Navigation (USB cable connection only): OS Android™ 5.0 or higher, phone manufacturer's USB cable and data plan for applicable feature(s)
- Apple CarPlay® compatibility requirements for connection:
 - UVO link with Navigation (USB cable connection only): iOS software 8.0 or higher, phone manufacturer's USB cable and data plan for applicable feature(s)
 - (Connection only): iOS software 10.0 and higher with data plan for applicable feature(s)
- It is recommended to always update your phone to the latest operating system release
- Wireless Android Auto™ system only works for certain Android models. Use the manufacturer's USB cable when wireless feature is not available

Refer to the Car Infotainment System Quick Reference Guide for more information.

QR CODE

Apple CarPlay® & Android Auto™ Video



*Refer to the inside front cover for more information on QR codes.
www.youtube.com/KiaFeatureVideos*

UVO link Activation*†1

Follow these steps to activate your UVO link system:

1. Enter the activation screen on your vehicle's head unit:
 - a. Press SETUP key
 - b. Press UVO icon
 - c. Press Activate UVO
2. Read and agree to Terms of Service and Privacy Policy and press SUBMIT
3. Enter number or email address to receive a verification code, then press SUBMIT
4. Follow these steps to receive your verification code using your phone SMS or email:
 - a. Check your phone SMS or email for verification code
 - b. Open the link in your SMS or email. A page will open requesting that you create your account

Note: If you already have a Kia Owners Portal account using the email or phone number as your login ID, you will need to provide your password prior to receiving the verification code.

UVO Assistance*†1

Virtual Assistant ⓘ ⓘ - Press to connect to a virtual assistant to hear information about the UVO features

UVO Voice Local Search UVO ⓘ ⓘ - Press to connect to the search function to find points of interest or other locations, like "cafe"

UVO Voice Local Search UVO ⓘ ⓘ (non-navigation systems) - Press to activate phone projection with Android Auto™ or Apple CarPlay® (smartphone must be connected via wireless or USB cable. See previous page for availability and setup

Roadside Assist ⓘ ⓘ - Press to connect to a Roadside Assistant where you can request vehicle towing services

REMINDER: These buttons may be located in the rearview mirror or the overhead console.

Driving while distracted can result in a loss of vehicle control that may lead to an accident, severe bodily injury, and death. The driver's primary responsibility is in the safe and legal operation of a vehicle, and any handheld devices, other equipment, or vehicle systems which take the driver's eyes, attention and focus away from the safe operation of a vehicle or which are not permissible by law should never be used during operation of the vehicle.

ALWAYS CHECK THE OWNER'S MANUAL FOR COMPLETE OPERATING INFORMATION AND SAFETY WARNINGS.

- c. Enter your first name, last name, email, phone number, an account password, and click CREATE ACCOUNT. A page will open displaying your verification code
- d. Enter the code in the head unit and press ACTIVATE
- e. Go back to the page with your verification code and press "I have entered my verification code." A link will be provided to download the Kia Access with UVO link app from your app store. After installing the app, log in and enjoy

REMINDER: This vehicle is not equipped with over-the-air system updates.

For further UVO link operations, refer to the Car Infotainment System Quick Reference Guide.

UVO link may be unavailable for model year 2022 vehicles sold or purchased in Massachusetts.

QR CODE

Kia Access with UVO link app Video



UVO Assistance Video



*Refer to the inside front cover for more information on QR codes.
www.youtube.com/KiaFeatureVideos*

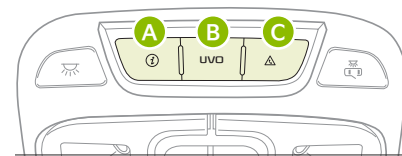

(Buttons on overhead console)*

For further UVO link operation, refer to the Car Infotainment System Quick Reference Guide. For further audio system operations, refer to pages 37-43.

Kia Access with UVO link App Download

Go to an app marketplace to download the Kia Access with UVO link App. Once you download the app, make sure you register your vehicle and start an account (refer to UVO link Activation page). Get to know your new Kia and the available convenient features on the app.

QUICK TIPS

- The smartphone and vehicle need to be connected to a cellular network with good wireless signal strength in order to use UVO. If these conditions are not met, remote command may not execute or may take a long time. It will also affect voice commands
- To use Remote Start or Remote Start with Climate Control feature, all doors, hood and trunk/liftgate must be closed and locked
- When Remote Start is activated, if the driver does not enter the vehicle within 10 minutes, the Remote Start will turn the engine off
- When using Remote Start with Climate Control, turn on for at least a few minutes before getting into the vehicle, allowing the vehicle interior to reach your desired temperature
- The quickest way to obtain accurate vehicle status through the app is by pressing the refresh button on the app or refreshing the web page when using the customer web portal
- In order to preserve the vehicle battery, UVO will not turn on seven days after the last ignition was on. You will need to restart the vehicle with a key fob in order to use UVO again
- Do not use remote climate control or remote start if vehicle is in an enclosed area (e.g., closed garage) or a partially enclosed area without ventilation. Close all doors leading from adjacent living areas to the vehicle area before executing a remote climate control or remote start command.



QR CODES

Download the Kia Access with UVO link App by clicking this dynamic QR code. Some phone's operating systems may need to be updated to scan dynamic QR codes.



Kia Access with UVO link App Features Guide. Click this dynamic QR code to access the guide. Some phone's operating systems may need to be updated to scan dynamic QR codes.



Kia Access with UVO link App Features Guide

The Kia Access with UVO link App Features Guide is a step-by-step guide helping you utilize the app to its full potential by detailing how to set up and use each feature and adjust various settings. Below are some of the topics included:

- Remote Commands
- Set Climate
- Schedule Remote Start/Climate
- Schedule Charge
- Schedule Service
- Dealer Settings
- Manage Vehicles and Profiles

Do not use remote climate control or remote start if vehicle is in an enclosed area (e.g., closed garage) or a partially enclosed area without ventilation. Close all doors leading from adjacent living areas to the vehicle area before executing a remote climate control or remote start command.

Kia App Screen for illustrative purposes only. Actual App screen and functionality may vary. For further UVO link operations, refer to the Car Infotainment System Quick Reference Guide.

UVO link with Navigation^{†1,8} - FM/AM/SiriusXM^{®†15}/Media (USB, *Bluetooth*^{®†3} Audio)

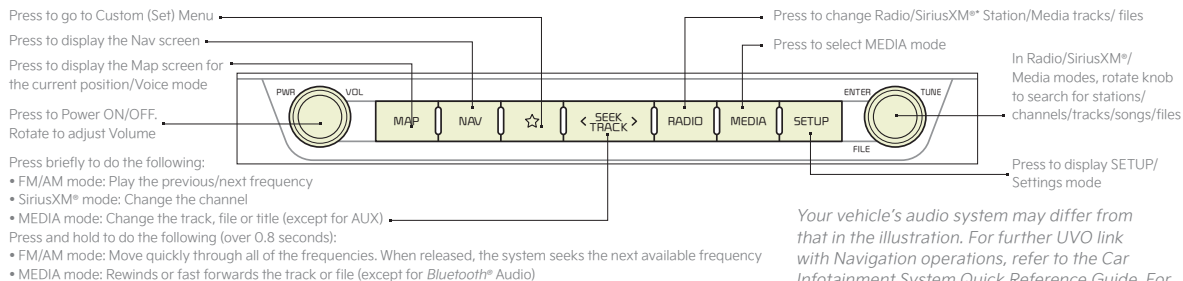

Your vehicle's audio system may differ from that in the illustration. For further UVO link with Navigation operations, refer to the Car Infotainment System Quick Reference Guide. For other audio system information, see pages 37-42.

QR CODE

UVO link with Navigation Videos



Refer to the inside front cover for more information on QR codes.
www.youtube.com/KiaFeatureVideos

Sound Settings - To adjust the sound settings:

1. Press the SETUP key on the audio head unit. Select the onscreen SOUND button
2. Select the menu item (Position, Tone, Priority, Advanced, Default)
3. Use the onscreen buttons to adjust settings. Press the return button to save settings

Radio Presets: You can listen to FM, AM and SiriusXM[®] radio and save frequently used stations. To save a preset, press and hold the desired slot or the STAR button next to or below the Radio Station display. This saves the current station in the selected slot.

SiriusXM[®] Smart Favorites: For the first ten favorite SiriusXM[®] channels, you may play live or repeat from the beginning of a song or a program segment. In Radio mode, choose SiriusXM[®], then select any of the first ten favorites. During song or program play, tap the Skip Backward icon to start from the beginning of the song or program. Tap the Play Live icon to return to the live broadcast.

Custom Key : A programmable key to provide quick access to one of several available system features. **To program the Custom Key**, press the SETUP key, then press and hold the Custom Key . Select one of the available features you would like the Custom Key to open.

Map/software updates - To keep your map and software up to date, free of charge, visit the official Kia update webpage at <https://update.kia.com/US/EN/Main>. **Note**, visiting a dealer for software update may include an additional charge.

QUICK TIPS

- Volume level between different audio modes:
 - When switching between audio modes (AM, FM, *Bluetooth*[®] Audio, etc.), the audio system saves the previous volume level you were listening to. For example, if you were listening to FM radio at volume level 20 then switched to *Bluetooth*[®] Audio and adjusted the volume level to 30, the volume level will be at 20 when you switch back to FM radio
 - When using *Bluetooth*[®] Audio, the overall volume is dependent on your device's volume. If the volume is turned down low on your device it will remain low even if the system volume is turned up
- To download map updates for the navigation system, go to <https://update.kia.com/US/EN/Main>. Check for updates that are generally available twice a year
- When connected to Android Auto[™] or Apple CarPlay[®] on your smartphone, the smartphone's navigation system may also be available
- This system supports Android Auto[™] and Apple CarPlay[®] (USB connection only)
- A warning screen may appear periodically to remind users that the navigation system should be operated when the vehicle power is on to prevent battery discharge
- At any time, you can interrupt UVO link Command Feedback by pressing the TALK button on the steering wheel

REMINDER: To help minimize driver distraction, some audio system functionalities have been modified while the vehicle is in Drive, Reverse or moved out of Park.

Driving while distracted is dangerous and should be avoided. Drivers should remain attentive to driving and always exercise caution when using the audio system controls while driving. To help minimize driver distraction, some audio system functionalities have been modified while the vehicle is in Drive, Reverse or moved out of Park.

UVO link may be unavailable for model year 2022 vehicles sold or purchased in Massachusetts. See UVO Terms of Service at owners.kia.com for more information.

Digital Clock

Press SETUP, then select General, then select Date/Time from the menu to adjust.

QUICK TIPS

- Press the Return button on the audio head unit to ensure changes are saved
- When needed, Daylight Savings must be enabled in the Clock Settings screen
- To access manual date and time setting, turn GPS time OFF in the Clock Settings (UVO link with Navigation*)

USB Charger Ports*

The USB Charger Ports **C** are located on the center panel and inside the Center Console. Devices can be recharged using a USB cable. The Power button needs to be in the ACC/ON/RUN/START position to operate the USB Charger Ports.

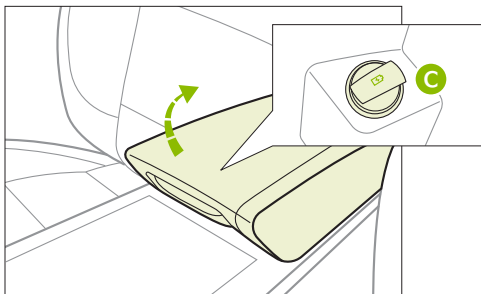

(Front of Center Console shown)

Multimedia USB Ports & Power Outlets*

Multimedia USB Port **A**

Use the Multimedia USB port to connect USB audio devices and smartphones.

Power Outlets **B**

Use the power outlet for mobile phones and other devices designed to operate on a 12V (180W max) power outlet.

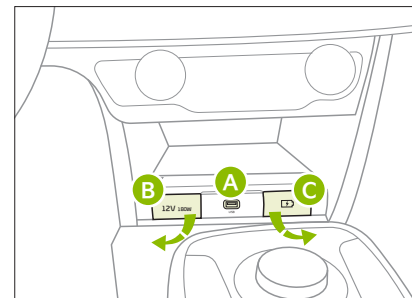

QUICK TIP

The power outlets are inactive when ignition is in the OFF position.

REMINDERS:

- Only use cables made by your device manufacturer. Third party cables may damage your device
- The Multimedia USB data port is located between the Power Outlet and USB Charger Port. The USB Charger Port does not support data transfer

Refer to section 4 in the Owner's Manual for more information.

For illustrative purposes only. Your actual display, buttons and/or features may vary.

Wireless Smartphone Charging System*

Charge a compatible smartphone wirelessly by placing it on the charging pad **A** at the front of the console, near the Multimedia USB ports and the charging indicator, while the ignition is on.

1. Enable Wireless Charging in the User Settings
2. Place a compatible smartphone on the center of the charging pad **A**
3. Indicator light **B** may change to amber once the wireless charging begins
4. Once charging is complete, the amber light may change to green

QUICK TIPS

- The smartphone must be a compatible phone with Qi function available
- Wireless charging must be enabled in user settings
- If wireless charging does not work, move smartphone around the pad until the charging indicator turns amber. Avoid placing other metal items in the bin while charging so as to not impede the charging area
- For wireless charging to occur, all doors (excluding rear hatch) must be closed & the Smart Key Fob must be detected inside the vehicle and driver's seat belt on

REMINDERS:

- Wireless charging technology allows for a device to be charged using inductive charging. See your Owner's Manual for more detailed information and the back page for legal disclaimers
- Inductive charging systems are less efficient than conventional charging through cable. As a result, higher device operating temperatures may be experienced during use
- Charging Performance - Device position on the wireless charging system can affect charging performance. Other factors that may affect the charging rate includes foreign objects, such as coins or pens, and phone case thickness
- If driver door is opened, charging will be disabled

Requires Qi enabled device or Qi enabled case

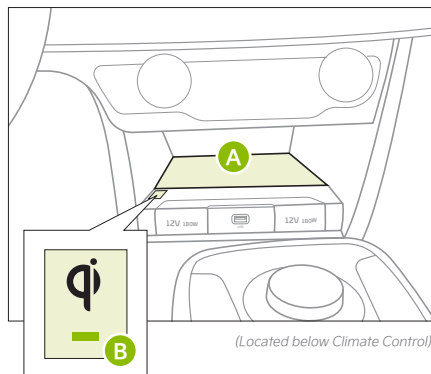

QR CODE

Wireless Charging Video



Refer to the inside front cover for more information on QR codes.
www.youtube.com/KiaFeatureVideos

Charging system only works with select devices. Refer to the section 4 in the Owner's Manual for warnings and instructions.

Images are for illustrative purposes only and may not reflect actual feature or operation.

Automatic Climate Control

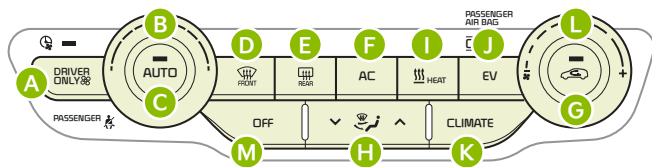

- A** Driver Only Fan Control
- B** Temperature Control knob
- C** Automatic Climate Control button
- D** Front Windshield Defroster
- E** Rear Windshield Defroster
- F** Air Conditioning On/Off button
- G** Recirculated Air button
- H** Air Flow Mode Selection button
- I** Heater on/off button
- J** EV menu button
- K** Climate information screen selection button
- L** Fan Speed Control knob
- M** System OFF button

Climate Control Auto Function

Press AUTO to select Full Auto Operation. The Auto setting automatically controls the airflow modes, fan speeds, air intake and air conditioning according to the temperature setting selected

Turn temperature control knob **B** to the desired temperature

QUICK TIPS

- Defrost mode activates A/C and opens Fresh Air Vent to help dehumidify the air and improve defog performance
- During Auto Operation, the A/C indicator will NOT illuminate. The fan speed, air intake, air flow and air conditioning may automatically be engaged at any time to reach desired temperature and reduce humidity
- Keep inside glass as clean as possible to reduce window fogging

Your Automatic Climate Control system may differ from those in the illustration. Refer to section 4 in the Owner's Manual for more information.

Auto Defogging System: Auto defogging is designed to reduce the fogging up of the inside of the windshield by automatically sensing the moisture of the inside of the windshield. The system will automatically change to defrost mode when needed.

Auto Defogging is set ON by default. To cancel Auto Defogging, press and hold the Front Defrost button for three seconds, when the ignition is in on (the defrost button light will flash three times and the ADS OFF icon will illuminate). To turn Auto Defogging on again, press and hold the Front Defrost button again for three seconds and the defrost button light will flash 6 times and ADS OFF icon will turn off.

Driver Only Ventilation: Driver Only Ventilation restricts air flow to the driver's side vents only. This can help to optimize driving range by limiting the power drawn from the battery. Press DRIVER ONLY button to enable air flow through the driver's side vents only.

Defrost Outside and/or Inside Windshield:

1. Set Front Fan Speed **G** to the highest position
2. Set **Temperature** to **Hot B**
3. Press the **Front Defrost** button **D**

Air Flow Modes **H**:

To select Air Flow Modes, press the Mode selection buttons:

- Face-Level
- Bi-Level
- Floor-Level
- Floor/Defrost-Level

REMINDERS:

- Continuous use of the climate control system in the recirculated air position may allow humidity to increase inside the vehicle which may fog the glass and obscure visibility
- Pressing any button during AUTO operation will deactivate the AUTO function and switch to manual mode, except for Temperature Control
- When in AUTO mode, Air Flow mode and Fan Speed do not display on the Climate Control Display
- Cold or warm ambient air may flow in through vents if Recirculated Air button is not pressed ON (LED lit)
- Continuous use of the A/C and heater may allow the Energy Consumption to increase, especially excessive use of the heater

QR CODE

Automatic Climate Control Operation Video



Auto Defogging System Video



Refer to the inside front cover for more information on QR codes.
www.youtube.com/KiaFeatureVideos

Rotary Dial Shifter Knob

Rotate dial for the following:

P: Park - Press to place in Park

R: Reverse

N: Neutral

D: Drive

P Release: (Park Release) - Press brake pedal and press the P Release button **A** to release the Parking Brake and rotate dial to R, D or N. P Release is for emergency/towing use and not used in normal daily driving

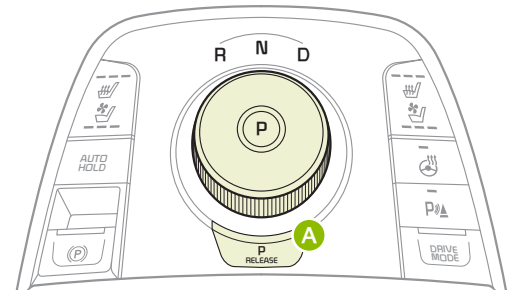

REMINDER: The vehicle is equipped with a shift-by-wire system and a shift-lock system that prevents you from shifting gears without depressing the brake pedal

Refer to section 5 in the Owner's Manual for more information.

Heated Steering Wheel Button*

Press button **B** to turn ON/OFF the steering wheel heater, while the POWER button is in the ON or READY position.

The steering wheel heater will turn off automatically after 30 minutes, or when button is pressed again to deactivate.

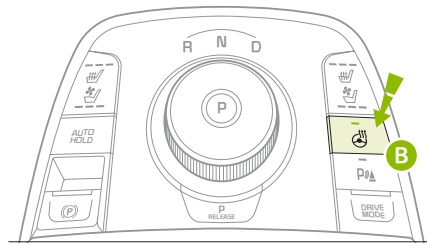

(Located to the right of Rotary Dial Shifter Knob)

QUICK TIP

If ignition is cycled, the Heated Steering Wheel turns OFF. Press button again to turn ON.

REMINDER: If the steering wheel becomes too warm, turn the system off. The heated steering wheel may cause burns even at low temperatures, especially if used for long periods of time.

Refer to section 4 in the Owner's Manual for more information.

Electronic Parking Brake (EPB)

The Electronic Parking Brake (EPB) system utilizes an electric motor to engage the parking brake.

Applying the Parking Brake

Pull up the EPB switch **A**. Ensure that the indicator light **ⓐ** is illuminated on the instrument cluster.

Releasing the Parking Brake

The EPB will automatically release when the brake pedal is engaged and shifter is shifted out of P (Park) to R (Reverse) or shifted out of N (Neutral) to Reverse or D (Drive).

Manually, depress the brake pedal, then press the EPB switch **A** down, with the ignition switch in the ON position. Ensure that the indicator light **ⓐ** is OFF.

QUICK TIPS

- When leaving your keys with parking lot attendants or valet, make sure to inform them how to operate the EPB
- If parked on a steep incline/decline, pull up the EPB switch for more than 3 seconds for a firmer EPB application
- Pull up and hold EPB switch again to increase brake pressure if parked on a decline or incline

REMINDERS:

- As a bulb check, the EPB malfunction indicator will illuminate for approximately 3 seconds when the ignition switch is turned ON
- If the warning light does not illuminate temporarily, or continues to remain lit, take your vehicle to an authorized Kia dealer and have the system checked
- The EPB should not be operated while the vehicle is moving
- A click or electric brake motor sound may be heard while operating or releasing the EPB, but these conditions are normal and indicate that the EPB is functioning properly

Refer to section 5 in the Owner's Manual for more information.

Auto Hold

Auto Hold temporarily maintains the vehicle at a standstill even if the brake pedal is released. Auto Hold can be turned ON/OFF using the AUTO HOLD switch **B** on the center panel. Before Auto Hold will operate, the driver's door, engine hood and trunk must be closed, and the driver's seat belt must be fastened.

The Auto Hold indicator has four states:

Standby (white): With vehicle in Park and at a standstill, and AUTO HOLD switch **B** turned ON, the indicator will illuminate white. While driving the vehicle (vehicle is not at a standstill), the Auto Hold indicator will remain white.

Engaged (green): When coming to a complete stop and depressing the brake pedal, the Auto Hold indicator changes from white to green.

OFF (not illuminated): The indicator will turn OFF when the AUTO HOLD switch **B** is turned OFF or when the EPB is manually turned ON.

Malfunction (yellow): When the indicator is illuminated yellow, there may be a system malfunction. Take your vehicle to a local Kia dealer.

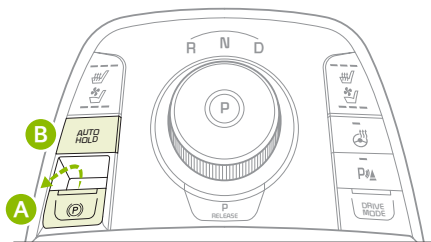

(Located below left of Rotary Dial Shifter Knob)

QR CODE

Electronic Parking Brake Video



Refer to the inside front cover for more information on QR codes.
www.youtube.com/KiaFeatureVideos

REMINDERS:

- To reduce the risk of an accident, do not activate Auto Hold while driving downhill, backing up or parking your vehicle
- Do not solely rely on the Auto Hold system to keep the vehicle stopped. Always pay attention to traffic and road conditions, and be prepared to depress the brakes
- Auto Hold turns off when ignition is cycled
- Auto Hold only operates when vehicle is in Drive, Neutral or Reverse

Refer to section 5 in the Owner's Manual for more information.

Seat Warmers / Ventilated Seats*†14 (Driver & Front Passenger)

Seat Warmers — Press top of the button once for high setting (3 amber LEDs lit), again for middle setting (2 amber LEDs lit), again for low setting (1 amber LED lit). Press again to turn OFF.

Ventilated Seats — Press bottom of button once for high setting (3 blue LEDs lit), again for middle setting (2 blue LEDs lit), again for low setting (1 blue LED lit). Press again to turn OFF.

QUICK TIPS

- With the seat warmer switch in the ON position, the heating system in the seat turns OFF or ON automatically depending on the seat temperature
- System is OFF by default

REMINDERS:

- Use extreme caution when using the seat warmers to avoid burns. Refer to the Owner's Manual for more information
- You can also press and hold buttons to turn off the seat heater / ventilation

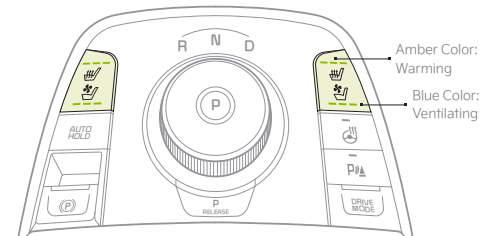

QR CODE

Seat Warmers / Ventilated Seats Video



Refer to the inside front cover for more information on QR codes.
www.youtube.com/KiaFeatureVideos

Refer to section 4 in the Owner's Manual for more information.

Front Seat Headrest Adjustment^{†7}

To raise headrest: Pull headrest up.

To lower headrest: Press lock **A**, then press the headrest down.

QUICK TIP

For easy adjustments, hold a headrest post with one hand while using the other hand to pull the headrest from underneath

REMINDERS:

- The headrest only moves up and down as described above. It does not adjust forward or backward
- Do not operate the vehicle with the headrests removed. Headrests can provide critical neck and head support in an accident

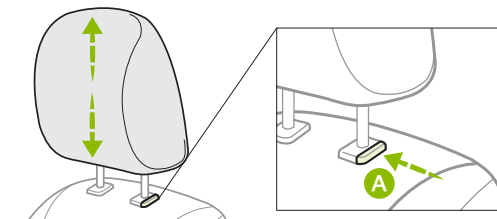

Power Adjustable Driver's Seat^{†12}

Move/Press controls to adjust Seat forward/backward, Seat Cushion tilt up/down, Seatback forward/backward or Lumbar forward/backward.

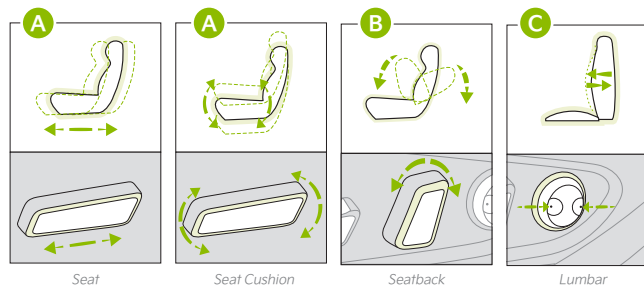
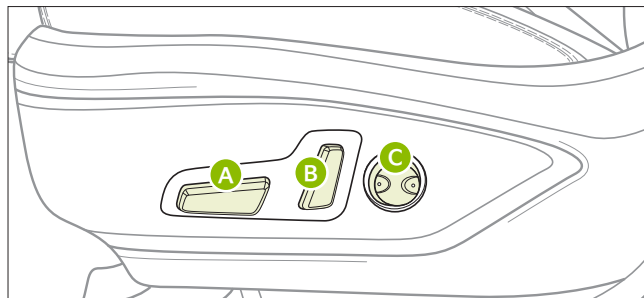

REMINDER: Do not attempt to adjust the seat while the vehicle is moving. This could result in loss of control of the vehicle.

Refer to section 3 in the Owner's Manual for more information.

Folding Rear Seats

To Fold:

1. Ensure the belt strap is out of way of the Seatback folding **D**. Insert the metal seat belt tab into the holder **E**
2. Adjust the Front Seatback to the upright position and lower the rear headrest to the lowest position
3. Pull on the Rear Seatback lock release lever **F**, then fold the seat toward the front

To Unfold:

1. Pull the lock release lever **F** and lift the Seatback backward until it clicks firmly in place
2. Return the rear seat belt to the proper position

QUICK TIPS

- It may be necessary to adjust the Front Seatbacks to fully lower rear seats
- Ensure seat is locked by pressing down on Seatback and ensuring red line is NOT visible on bottom of Folder Lever

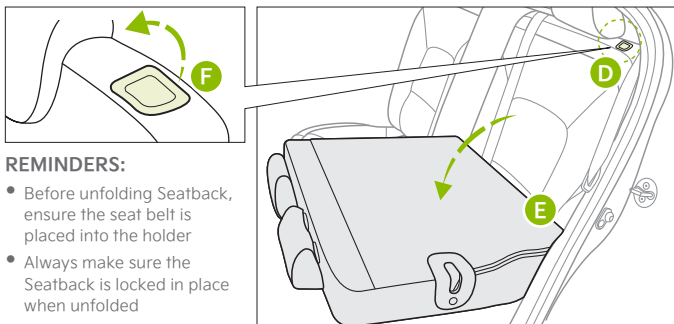

REMINDERS:

- Before unfolding Seatback, ensure the seat belt is placed into the holder
- Always make sure the Seatback is locked in place when unfolded

For illustration purposes only. Actual vehicle might be slightly different. Refer to section 3 in the Owner's Manual for more information.

Hood Release Lever and Latch

Opening the Hood:

Pull the Hood Release Lever **A** to unlatch the Hood

In the front of the vehicle, lift the Hood slightly, pull the secondary Latch **B** inside of the Hood's center to the left and lift the Hood

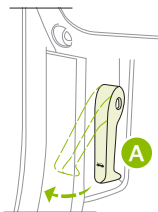

(Located on Driver side kick panel)

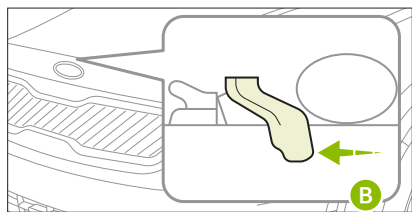

(Latch located inside hood)

Closing the Hood: Lower the Hood about halfway and then press down to securely lock in place.

Refer to section 4 in the Owner's Manual for more information.

Sunvisor^{†17}

Use the Sunvisor to shield direct light through the front or side windows. Slide the Sunvisor out and adjust as needed.

REMINDERS:

- Sunvisor may not shield all direct light
- Do not operate the vehicle if Sunvisor is impairing your visibility
- Be aware of your seating position when adjusting or swinging Sunvisor around from the front or side windows

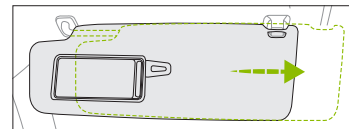

Refer to section 4 in the Owner's Manual for more information.

Smart Key†10

Smart Key Fob:

- A** Press to lock All Doors; Press twice within 2 seconds to sound the horn
- B** Press to unlock Driver's Door. Press twice in 4 seconds to unlock All Doors
- C** Press and hold for more than 1 second to unlock Liftgate. Then lift the liftgate handle to manually open Liftgate

REMINDER: The Liftgate unlocks when the Smart Key fob is within close proximity of the vehicle Liftgate.

- D** Press and hold more than 1 second for Panic Alarm. To turn off Alarm, press any button
- E** Press to release Mechanical Key (on reverse side of fob)

Driver's Door Lock/Unlock button **F**:

- Press button once to unlock Driver's Door
- Press again within 4 seconds to unlock All Doors
- Press again to lock All Doors

Mechanical Key **G**:

- Use to lock/unlock Driver's Door by turning once or all doors by turning twice
- Use to enable/disable Child Safety Locks
- Use to unlatch rear center seatbelt lower anchor

Remote Start* **H:** Lock the doors by pressing the door lock button **A** within 32 feet distance from the vehicle. Within four (4) seconds of pressing the door lock button **A**, press and hold the Remote Start button **D** for more than two (2) seconds to start the vehicle. To stop the Remote Start operation, press the button again. If driver does not enter vehicle within three minutes of starting the vehicle, the vehicle will automatically turn off.

QUICK TIPS

- If the Smart Key battery is weak or not working properly, hold the Smart Key fob up to the POWER button (Lock button side closest) and press to start vehicle
- The Smart Key's signal can be blocked by the normal operation of a cell phone or smartphone. To help prevent this, store each device separately

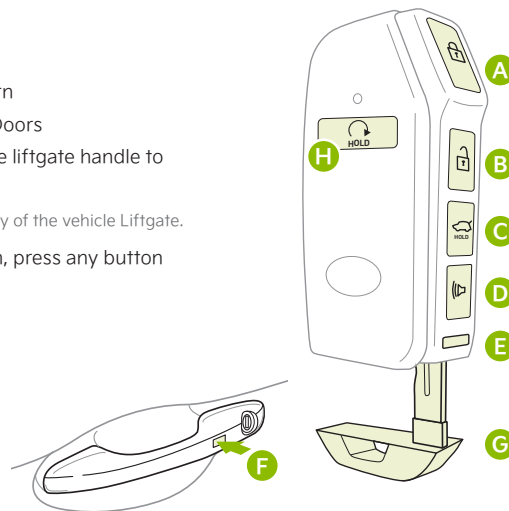

Double-Turn Lock/Unlock All

- Turn counterclockwise once to unlock Driver's Door
- Turn counterclockwise again within 4 seconds to unlock All Doors
- Turn clockwise once to lock All Doors

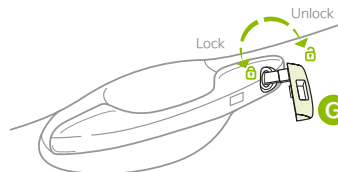

Images are for illustrative purposes only and may not reflect actual feature or operation.

QR CODE

Remote Start - Smart Key Video



Kia Smart & Folding Key Fobs Video



*Refer to the inside front cover for more information on QR codes.
www.youtube.com/KiaFeatureVideos*

REMINDEES:

- Remote button configuration may vary depending on vehicle options
- One/two button turn logic can be changed in User Settings
- When reinserting the mechanical key, make sure it is pushed all the way in until there is a click sound.

Refer to section 4 in the Owner's Manual for more information.

Map/Room Lamps

Automatic turn off function*

The interior lights automatically turn off approximately 30 seconds after the POWER button is turned OFF.

Map Lamp/Room Lamp Operation

- Press lens **A** to turn the Driver's/ Passenger's Map Lamps ON/OFF. This light produces a spot beam for convenient use as a map lamp or as a personal lamp for the driver or the front passenger.
- Press button **B** to turn all the Map/Room Lamps ON/OFF
- Press button **C** to turn the Map/Room Lamp ON, for 30 seconds, when a door is opened, unlocked from Smart Key or the ignition is turned OFF. When pressed and a door is opened, or doors are unlocked from the Smart Key, the Map and Room Lamps turn ON for approximately 30 seconds.
- Press button **D** to turn the Room Lamp ON/OFF

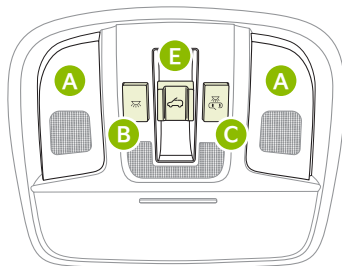

(Type B*)

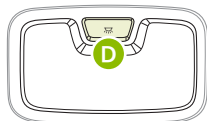

QUICK TIPS

- When doors are unlocked by the Smart Key*, the lamp turns ON for approximately 30 seconds
- If your vehicle is equipped with the theft alarm system, the interior lights automatically turn off approximately 3 seconds after the system is in armed stage
- Using interior lights for an extended period of time may cause 12V battery discharge

Sunroof Operation*

The Sunroof and Sunshade operation is controlled through a multidirectional switch/lever, and the ignition needs to be in the ON position to operate the Sunroof/Sunshade.

Slide the Sunshade and Sunroof:

- **Auto Open:** Slide lever **E** backward to the farthest position and release
- **Auto Close (Sunroof only):** Slide the lever **E** forward to the farthest position and release

Slide the Sunroof (with Sunshade open):

- **Open:** Press the Sunroof lever **E** backward and press again forward/backward until you reach the desired detent position (manual slide feature)
- **Close:** Press the Sunroof lever **E** forward and press again forward/backward until you reach the desired detent position (manual slide feature)

Tilt the Sunroof:

- **Raise:** Push lever **E** upward
- **Lower:** Push lever **E** forward

QUICK TIPS

- To stop the Sunroof at any position, push or pull the Sunroof control lever in any direction
- Adjusting the sunroof past the first stop position (normal), in the fully opened position, may cause wind buffeting noise

REMINDERS:

- Sunshade needs to remain OPEN while Sunroof is open and vehicle is moving
- When closing, be mindful of any objects or persons

Do not adjust the sunroof or sunshade while driving. This could result in loss of control of the vehicle.

QR CODE

Sunroof Operation Video



*Refer to the inside front cover for more information on QR codes.
www.youtube.com/KiaFeatureVideos*

Refer to section 4 in the Owner's Manual for more information.

Liftgate Release Button*†20

The button is located on the bottom of the Liftgate lid. With doors unlocked, press the Liftgate Release button **A** and pull the Liftgate up by the handle to open.

QUICK TIPS

- The Liftgate must be unlocked before it can be opened by the Liftgate Release Button
- The Liftgate unlocks automatically and then can be opened manually when the Smart Key* is within close proximity to the vehicle

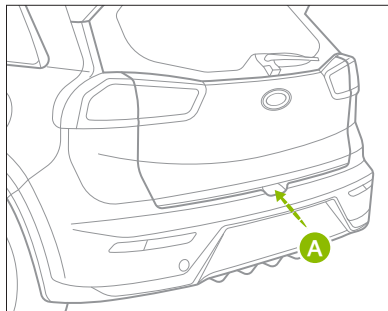

REMINDER: Pressing the Smart Key remote liftgate button only unlocks the liftgate. To open liftgate, also press the Liftgate Release button & pull the liftgate up by the handle to open.

Refer to section 4 in the Owner's Manual for more information.

Child-Protector Rear Door Lock

Locate these locks on the rear edge of the rear passenger doors. Move the Child-Protector Rear Door Lock, with the mechanical ignition key, to the lock position  to disable the inner door handles from opening the rear doors.

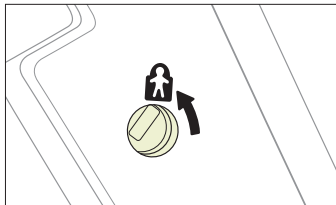

REMINDER: Child-Protector Rear Door Lock is located on rear passenger's door jamb.

Refer to section 3 in the Owner's Manual for more information.

Tire Mobility Kit

The Tire Mobility Kit is designed to temporarily seal certain types of tire damage.

For operational information, please refer to the Owner's Manual.

- B** Sealant Bottle
- C** Compressor

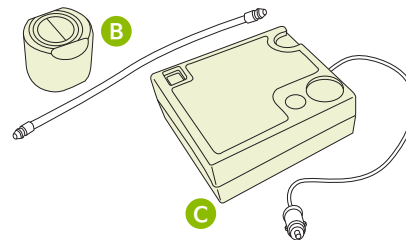

QUICK TIPS

- The Tire Mobility Kit is a temporary fix and is to be used for one tire only; the tire should be inspected as soon as possible
- The kit should only be used for sealing/inflating passenger car tires; do not use for inflating any other type of tires
- Some damaged tires cannot be sealed completely; do not use the kit if it appears a tire is damaged beyond repair

REMINERS:

- The above images are for illustration purposes only and may not reflect actual operation
- After tire is properly sealed, drive cautiously and never exceed 50 mph or 120 miles on a tire that has been properly sealed with the Tire Mobility Kit
- Accessory spare tire kit is available for purchase

QR CODE

Tire Mobility Kit Video



Refer to the inside front cover for more information on QR codes.
www.youtube.com/KiaFeatureVideos

Refer to section 6 in the Owner's Manual for more information.

Occupant Detection System (ODS)⁺⁹ / Passenger Airbag Off Indicator⁺²

ODS is designed to detect the presence and position of the front passenger and adjusts or turns off airbag deployment accordingly.

Depending on the situation and type of accident, the system may:

- Deploy airbag (Adult)
- Not deploy the airbag (Unoccupied)

If the system determines that the airbag should not be deployed, the "PASSENGER AIR BAG OFF" light will illuminate.



REMINDERS:

- Do not allow an adult passenger to ride in the front seat when the Passenger Airbag Indicator is illuminated OFF because the airbag will not deploy in the event of a crash. The driver must instruct the passenger to reposition her/himself in the seat, or move to another seat in the vehicle
- For more information on the Occupant Detection System/ Passenger Airbag Off Indicator, please refer to the Owner's Manual

QUICK TIPS

The Seat Belt warning chime operates for driver's seat only.

REMINDER: For maximum protection, always wear your Seat Belt.

Refer to section 3 in the Owner's Manual for more information.

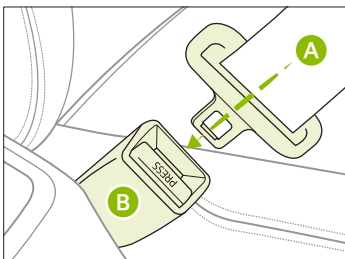

Seat Belts⁺¹³

To properly fasten your safety belts:

1. Insert the belt tongue plate **A** into the buckle **B** until it clicks
2. Position the lap portion of the belt across your lap as LOW ON THE HIPS as possible **C**. Adjust the belt to a SNUG FIT by pulling up on the shoulder portion **D**.

Seat belt retractor locks:

Retractor locks allow lap/shoulder seat belts to remain unlocked during normal vehicle operation for freedom of movement and increased comfort.

During a STRONG STOP, SUDDEN TURN OR CERTAIN COLLISIONS, seat belt retractors will automatically lock the belts to reduce the risk of injury.

Refer to section 3 in the Owner's Manual for more information.

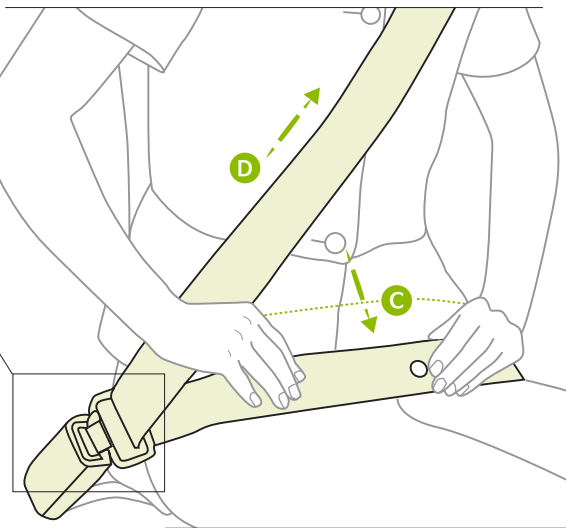

LEGAL DISCLAIMERS

Driving while distracted can result in a loss of vehicle control that may lead to an accident, severe personal injury and death. The driver's primary responsibility is in the safe and legal operation of a vehicle. Handheld devices, other equipment or vehicle systems which take the driver's eyes, attention and focus away from the safe operation of a vehicle or that are not permissible by law should never be used during operation of the vehicle.

Safety Features: No system, no matter how advanced, can compensate for all driver error and/or driving conditions. Always drive safely.

- 1. UVO Link:** Purchase/lease of certain 2022 and newer Kia vehicles with UVO link includes a complimentary 1-year subscription starting from new vehicle retail sale/lease date as recorded by the dealer. After your complimentary 1-year UVO link subscription expires, continued access to the full suite of UVO link services available on your Kia will require a paid subscription at the then-current subscription rate or your use of certain UVO link features may immediately terminate. Use of UVO is subject to agreement to the UVO Privacy Policy (available at owners.kia.com/us/en/privacy-policy.html) and Terms of Service (available at owners.kia.com/us/en/terms-of-service.html). Complimentary UVO link subscription is transferable to subsequent owner during the original UVO link service term. Only use UVO link when safe to do so. UVO Link may currently be unavailable for Model Year 2022 and newer vehicles sold or purchased in Massachusetts; please see the Kia Owners Portal for updates on availability. Kia Access with UVO link app is available from the Apple® App Store® or Google Play Store™. Kia America, Inc. reserves the right to change or discontinue UVO link at any time without prior notification or incurring any future obligation. Message and data rates may apply. Cellular and GPS coverage is required to use most features. UVO link features may vary by model, model year, and trim level. Features, specifications, and fees are subject to change. For more on details and limitations, visit www.kia.com or your authorized Kia dealer. Apple® and App Store® are registered trademarks of Apple Inc. Google™ and its logos are trademarks of Google LLC.
- 2. Airbags:** For maximum protection, always wear your seat belt.
- 3. Android Auto™, Apple CarPlay®, Bluetooth® Wireless Technology, Google Play™ Store, iPhone, SiriusXM®, Sportmatic®:** Fair Use of Trademark - The commentary reference to trademarked material is for educational purposes only and not an endorsement by or of the holder of the mark.
- 4. Driver Assist Features - Forward Collision-Avoidance Assist (FCA) / Forward Collision Warning (FCW), Blind-Spot Collision Warning (BCW), Rear Cross-Traffic Collision Warning (RCCW), Lane Keeping Assist (LKA), Lane Following Assist (LFA), Rear View Monitor, Reverse Parking Distance Warning (PDW)™, Smart Cruise Control (SCC) with Stop & Go, Navigation-based Smart Cruise Control (NSCC), Highway Driving Assist (HDA), Leading Vehicle Departure Alert (LVDA):** When engaged, these features are not substitutes for safe driving, and may not detect all objects surrounding vehicle. Always drive safely and use caution.
- 5. Driver Attention Warning (DAW):** When engaged, Driver Attention Warning is not a substitute for safe driving and may not detect all instances of driver fatigue or inattentive driving practices. Failure to pay attention to travel conditions and vehicle operation could result in loss of vehicle control. Always drive safely and use caution.
- 6. Electronic Stability Control (ESC)/ Traction Control System (TCS)/Hill-Start Assist Control (HAC):** No system, no matter how advanced, can compensate for all driver error and/or driving conditions. Always drive safely.
- 7. Front Seat Headrest Adjustment:** Never attempt to adjust headrests when vehicle is in motion.
- 8. Navigation:** Distracted driving can result in a loss of vehicle control. When operating a vehicle, never use a vehicle system that takes your focus away from safe vehicle operation. Navigation is for information purposes only, and Kia does not make any warranties about the accuracy of the information.
- 9. Occupant Detection System (ODS):** Kia vehicles use a number of different ODS types that vary by model. Children age 12 and under should always be seated in the REAR seats.
- 10. Power Button with Smart Key:** Always come to a complete stop before turning the power on or off. However, if you have an emergency while the vehicle is in motion and must turn the power off, you can turn the power off to the ACC position by pressing the Power button for more than 3 seconds or 3 times in succession. If the vehicle is still moving, you can restart the power by pressing the Power button with the shift lever in Neutral (N). With the power off, hydraulic power assist for steering and braking will be disabled and the vehicle will be more difficult to control.
- 11. Roadside Assist:** 24-hour Enhanced Roadside Assistance is a service plan provided by Kia America, Inc. Certain limitations apply. Coverage details are available in the Kia Warranty and Consumer Information Manual. On certain audio systems, for access to Enhanced Roadside Assistance*, a connected mobile phone via *Bluetooth®* within the cellular service coverage area is required.
- 12. Seat adjustments:** Reclining the passenger seats can reduce the effectiveness of the safety restraint system and may lead to additional injury in an accident.
- 13. Seat belts:** For maximum protection, always wear your seatbelt.
- 14. Seat warmers:** Use extreme caution when using the seat warmers to avoid burns. Refer to the Owner's Manual for more information.
- 15. SiriusXM®:** SiriusXM Satellite Radio, SiriusXM Traffic and SiriusXM Travel Link each require a subscription sold separately, or as a package, by SiriusXM Radio Inc. If you decide to continue your service at the end of your trial subscription, the plan you choose will automatically renew and bill at then-current rates until you call 1-866-635-2349 to cancel. See SiriusXM Customer Agreement for complete terms at www.siriusxm.com. Other fees and taxes will apply. All fees and programming are subject to change. Not all vehicles or devices are capable of receiving all services offered by SiriusXM. Data displays and individual product availability vary by vehicle hardware. Current information and features may not be available in all locations, or on all receivers. Weather Forecast, Current Conditions may not be available in all locations. Images above are for representative purposes only and are not real products. For actual features and images of real products, consult the vehicle manufacturer. SiriusXM is not responsible for any errors or inaccuracies in the data services or their use in the vehicle. Travel Link Stocks displays current price and daily delta of around 7,000 actively reported securities traded on the NYSE®, NASDAQ® and AMEX®. The service is delayed approximately 20 minutes. SiriusXM satellite service is available only to those at least 18 years of age in the 48 contiguous USA, DC, and Puerto Rico (with coverage limitations). SiriusXM Internet Radio service is available throughout our satellite service area and in AK and HI. © 2021 SiriusXM Radio Inc. Sirius, XM and all related marks and logos are trademarks of SiriusXM Radio Inc.
- 16. Steering-wheel-mounted controls:** Driving while distracted is dangerous and should be avoided. Remain attentive to driving and be cautious when using steering-wheel-mounted controls while driving.
- 17. Sunvisors:** Sunvisor may not shield all direct light. Do not operate the vehicle if sunvisor is impairing your visibility.
- 18. Tilt/Telescoping Steering Wheel:** Never attempt to adjust steering wheel position when vehicle is in motion.
- 19. Tire Pressure Monitoring System (TPMS):** Even with Tire Pressure Monitoring System, check tire pressure on a regular basis.
- 20. Liftgate:** Driving with the liftgate open may be unlawful and can draw dangerous exhaust fumes into your vehicle; if you choose to do so, keep air vents and all windows open for improved ventilation.



KEY FEATURE WALKTHROUGH

Demonstrate the following with the customer:

- Android Auto™ / Apple CarPlay® Setup* - page 40
- UVO link Activation / UVO Assistance* - page 41

Walk customer through the registration/activation process for UVO link



- UVO link with Navigation* - page 43

For further operational information, refer to the Car Infotainment System Quick Reference Guide.

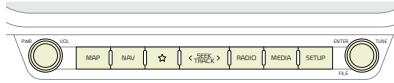

- Multimedia USB Port & Power Outlets - page 44

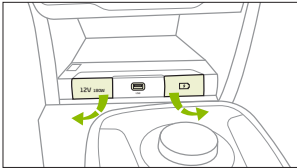

- Cruise Control / Smart Cruise Control with Stop & Go - pages 26-27

Demonstrate operation.

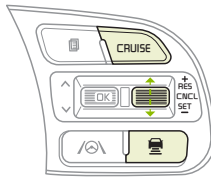

- Bluetooth® Wireless Technology - page 38-39

Demonstrate operation, and pair customer's phone.

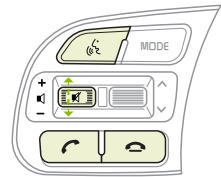

- Tire Pressure Monitoring System (TPMS) - page 8
- Trip Modes / Trip Computer - page 9
- Energy Consumption - page 5
- Drive Modes - page 12
- Power Button - page 32
- Audio Controls - page 37
- Digital Clock - page 44

- Seat Warmers/Ventilated Seats* - page 49
- Sunvisor - page 52
- Smart Key - page 53
- Reverse Parking Distance Warning (PDW)* - page 30
- Rear View Monitor (RVM) - page 30
- Tire Mobility Kit - page 55
- Passenger Airbag Off Indicator - page 56

DURING DELIVERY

- Explain first service process and schedule first service appointment
- Tour Parts & Service departments, introduce staff & explain value of Kia Parts and Service
- Review recommended maintenance schedule and maintenance requirements to validate warranty
- Review business hours
- Review the Kia 10-year/100,000-mile warranty program
- Ensure 100% satisfaction with sales and delivery process and no problems with the vehicle
- Confirm time and best contact number for initial dealer follow-up

*IF EQUIPPED

Sales Consultant: _____ Date: _____

Sales Manager: _____ Date: _____

Customer: _____ Date: _____



NIRO EV DELIVERY CHECKLIST

Owner's Name: _____ VIN: _____ Mileage: _____

Dealership Name: _____ Sales Consultant: _____ Date: _____

BEFORE DELIVERY

- Test and confirm "Good Battery" using a Kia battery tester and affix Results Label
- Verify all tire pressures are to spec (see driver's door label) LF _____ LR _____ RF _____ RR _____
- Verify proper operation of Remote Keyless Entry and Smart Key lock/unlock
- Ensure floor mats are snapped into place (if applicable)
- Verify vehicle is clean (interior and exterior), in good condition and free of chips and scratches
- Ensure all key documents are in the vehicle (Owner's Manual, Warranty and Consumer Information booklet, Tire Warranty booklet and Features & Functions Guide and any Audio System User's Manual)

KEY FEATURE WALKTHROUGH

- Instrument Cluster / EV Displays - pages 03-05

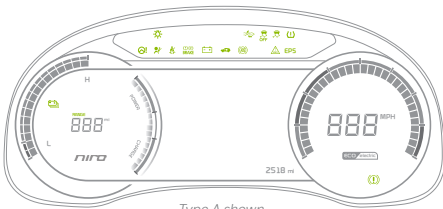

Type A shown

- EV Mode Displays* on the audio head unit - page 16

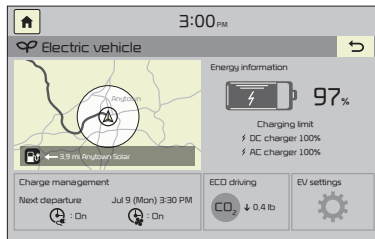

- Climate Control System* - page 36
Demo Defrost and Defog Windshield

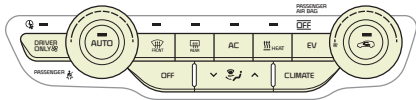

Type B shown

- Windshield/Rear Wipers & Washers - page 36

Windshield: Move lever Up/Down to change Wiper modes. Rotate lever to adjust Intermittent Wipe Speed.

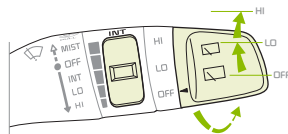

Windshield
 MIST: Single wipe
 OFF: Wipe off
 INT: Intermittent wipe
 LO: Slow wipe
 HI: Fast wipe

Pull to spray and wipe.



NIRO EV NORMAL MAINTENANCE SCHEDULE

P=Perform R=Replace I=Inspect^B

(up to 60,000 miles)^A

MAINTENANCE ITEMS	MAINTENANCE INTERVALS (MILES)							
	7,500	15,000	22,500	30,000	37,500	45,000	52,500	60,000
Check tire pressure and tread wear; Rotate tires (every 7,500 miles)	P	P	P	P	P	P	P	P
Climate control air filter †	I	R	I	R	I	R	I	R
12V battery condition	I	I	I	I	I	I	I	I
Steering gear rack, linkage & boots	I	I	I	I	I	I	I	I
Air conditioner refrigerant/compressor †	I	I	I	I	I	I	I	I
Brake fluid	I	I	I	I	I	I	I	R
Brake lines, hoses and connections	I	I	I	I	I	I	I	I
Disc brakes and pads	I	I	I	I	I	I	I	I
Brake pedal	I	I	I	I	I	I	I	I
Drive shafts and boots	I	I	I	I	I	I	I	I
Suspension ball bolts	I	I	I	I	I	I	I	I
Reduction Gear Oil			I		I		I	
Coolant System				I		I		I
Coolant					R			

QUICK TIP

Check your Maintenance Schedule or schedule an appointment with a dealer using your UVO link[®] account by logging into UVO link App or your account on <https://owners.Kia.com> (See page 41 for setup information)

‡ If equipped.

A. See the Owner's Manual for complete maintenance schedule.

B. And, if necessary, adjust, correct, clean or replace.

See your Owner's Manual for more details and complete maintenance information, including severe maintenance schedule. Warranty may be voided if maintenance schedule is not followed.

© 2021 Kia America, Inc. All rights reserved.

Consumer - Roadside Assistance¹¹: 1-800-333-4KIA (4542)

Part Number: DEEV210-PS-004

‡ If equipped

†LEGAL DISCLAIMERS ON BACK INSIDE COVER